

BROADBAND OVERMOLDED WHIP

225 - 512 MHZ 10W

R380.000.178

Series : ANTENNA

DÉTAIL A
Scale 2 : 1

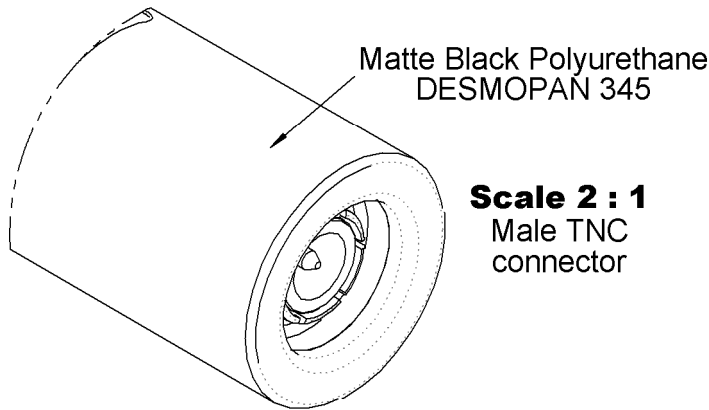
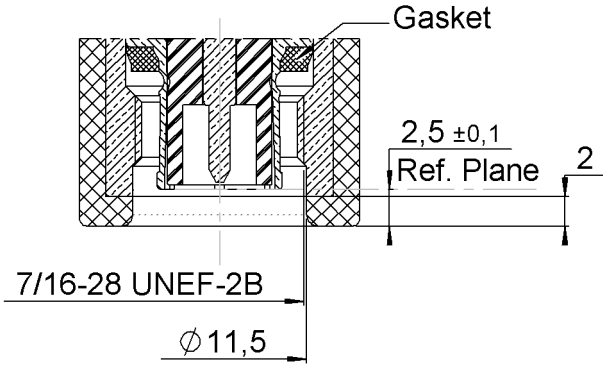

Scale 1 : 1
Matching unit TNC interface

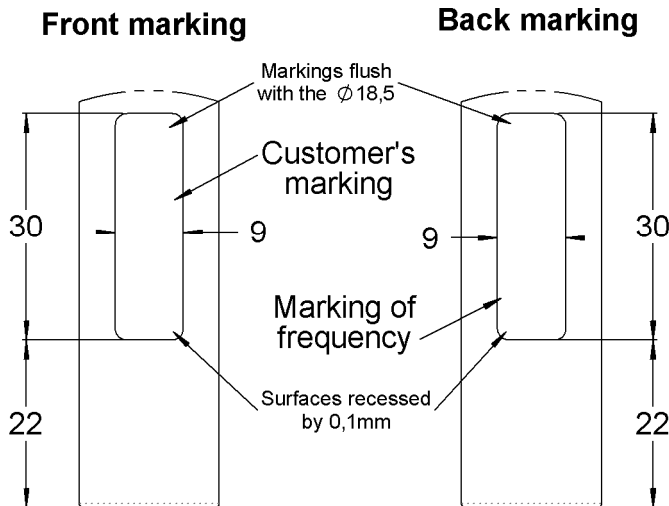

All dimensions are in mm

Scale 1 : 2

ROJONE
Australian Representatives
ROJONE, PTY LTD.
Tel: 02 9829 1555
E: sales@rojone.com.au
www.rojone.com.au

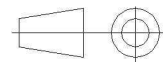
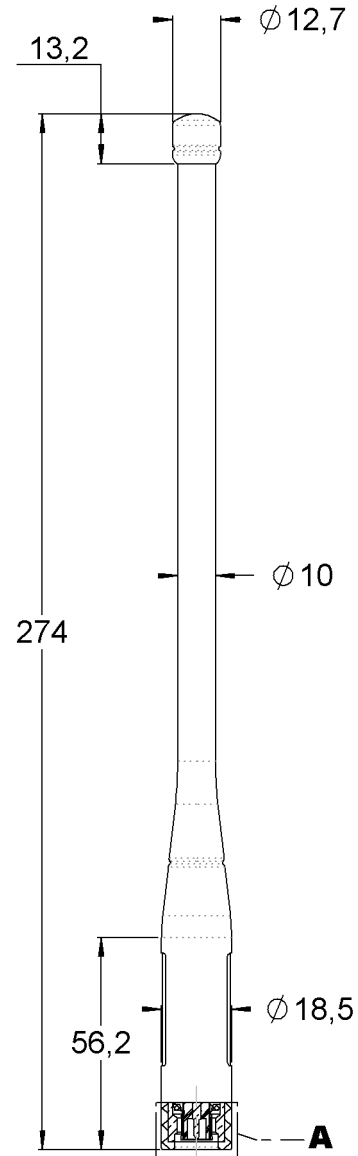

Issue : 1250 A

In the effort to improve our products, we reserve the right to make changes judged to be necessary.



BROADBAND OVERMOLDED WHIP

225 - 512 MHZ 10W

R380.000.178

Series : ANTENNA

ELECTRICAL CHARACTERISTICS

(Measurement on HandHeld radio 5 x 7 x 20 cm)

Frequency :	225-512 MHz
Nominal Impedance:	50 Ω
VSWR (stand alone) :	3:1 Max
VSWR (Walkie Talkie) :.....	3:1 Max
Gain (typical) :.....	
Peak Gain @ 225-512 MHz:.....	-1.5 to 2.2 dBi
(cf to typical gain curve):	
Radiation Pattern	
Horizontal Plane (Θ=90°):	Omni-directional
Vertical Plane (Φ=0°/90):	Dipolar
Polarization :.....	LINEAR VERTICAL
Power withstanding :.....	10 W Maxi
Connector type :	Male TNC

MECHANICAL CHARACTERISTICS

Antenna material :	TPU, DESMOPAN 345
Antenna color :	MATTE BLACK
Antenna texture :	Mold-Tech MT 11030
Overmolding flexibility:.....	+/- 180° - 500 cycles
Overmolding pull strength:	50 N
Maximum mating torque :	22.2 N.cm
Weight :	90 g
Overall length :	274 mm

ENVIRONMENTAL CHARACTERISTICS

Operating temperature :.....	-30/+60 ° C
Storage Temperature :	-35/+70 ° C
Humidity:.....	93% @ 30°C IEC 68-2-56Cb
Immersion :.....	20 m during 2 hours

Issue : 1250 A

In the effort to improve our products, we reserve the right to make changes judged to be necessary.



BROADBAND OVERMOLDED WHIP

225 - 512 MHZ 10W

R380.000.178

Series : ANTENNA

CURVES

Gain in Azimutal Plane on a 5 x 7 x 20cm Terminal

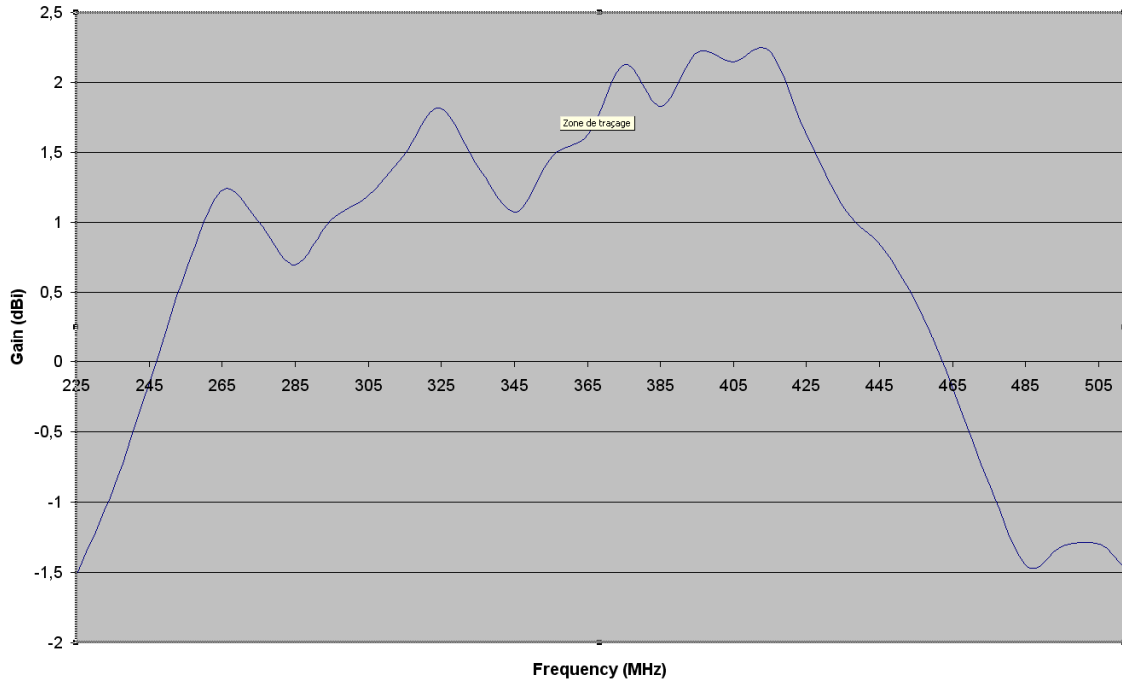

VSWR

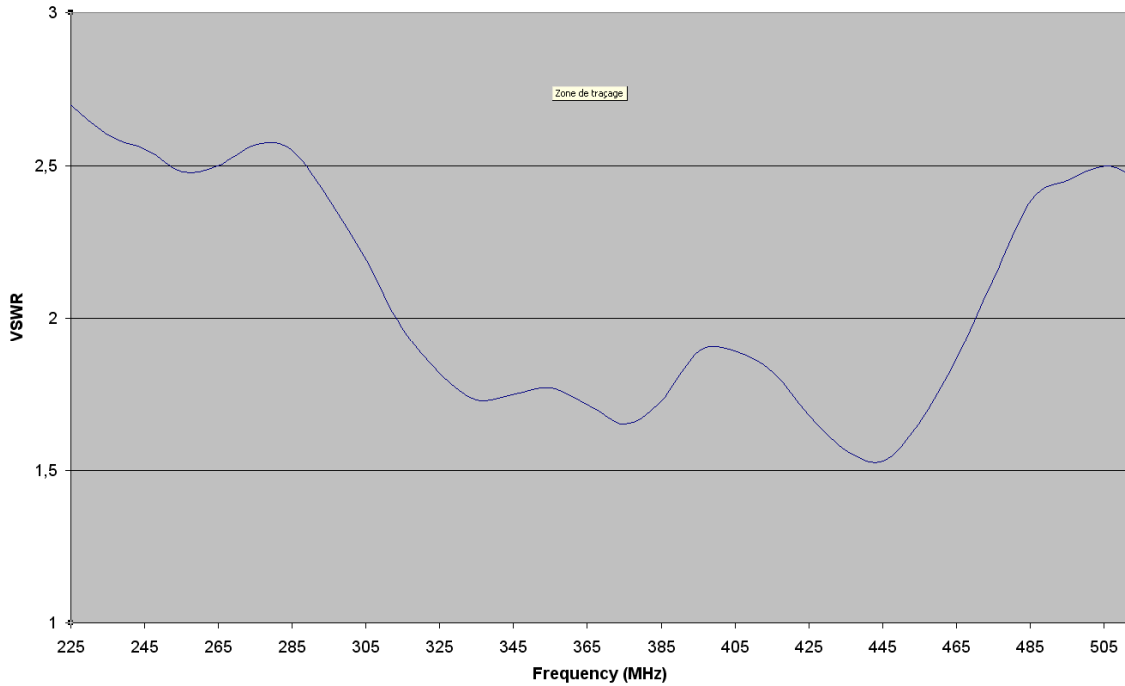

Issue : 1250 A

In the effort to improve our products, we reserve the right to make changes judged to be necessary.



Australian Representatives
ROJONE, PTY LTD.
 Tel: 02 9829 1555
 E: sales@rojone.com.au
 www.rojone.com.au