



Directional Panel Antenna for 4900 - 5875 MHz

(Model: A-5G-090250)

Electrical Specifications

Frequency Range	4900-5875 MHz
Gain	17-18 dBi
VSWR	2.0 : 1 max.
Polarisation	Linear, Vertical
HPBW / horizontal	17.5°~23°
HPBW / vertical	16°~19°
Sidelobe Level	Co-pol: -11.5 dB max. Cross-pol: -18 dB max.
Front-to-back ratio	-21 dB max.
Isolation	N/A
Power handling	5W (cw)
Impedance	50 Ohm
Cable	N/A
Connector	N Jack
Lightning Protection	DC ground

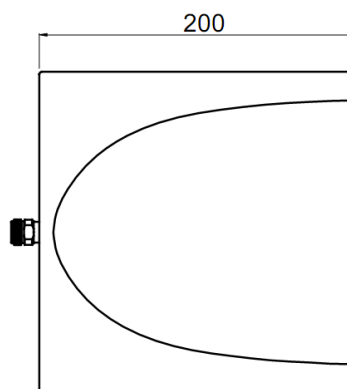

Environmental & Mechanical Characteristics

Survival Wind Speed	216 km/h
Temperature	-40°C to +80°C
Humidity	95% @ 55°C
Radome Colour	Grey
Radome Material	ABS, UV resistant
Weight	0.825 kg
Dimensions	114 x 114 x 40 mm
Waterproof	IP-X5
Mount Kit	Pole Mount

