

- NOTES:
1. EACH PART SHALL BE MARKED WITH U-92A/U & M9177/3-1.
  2. PART SHALL BE ON QUALIFIED PRODUCT LIST FOR MIL-C-9177/3A.
  3. CRIMPING TOOLS USE M22520/5-01 HAND TOOL W/CRIMP DIE M22520/5-29, M22520/5-35 OR M22520/5-55.
  4. MATING CONNECTORS M9177/1-1 & M9177/2-1.

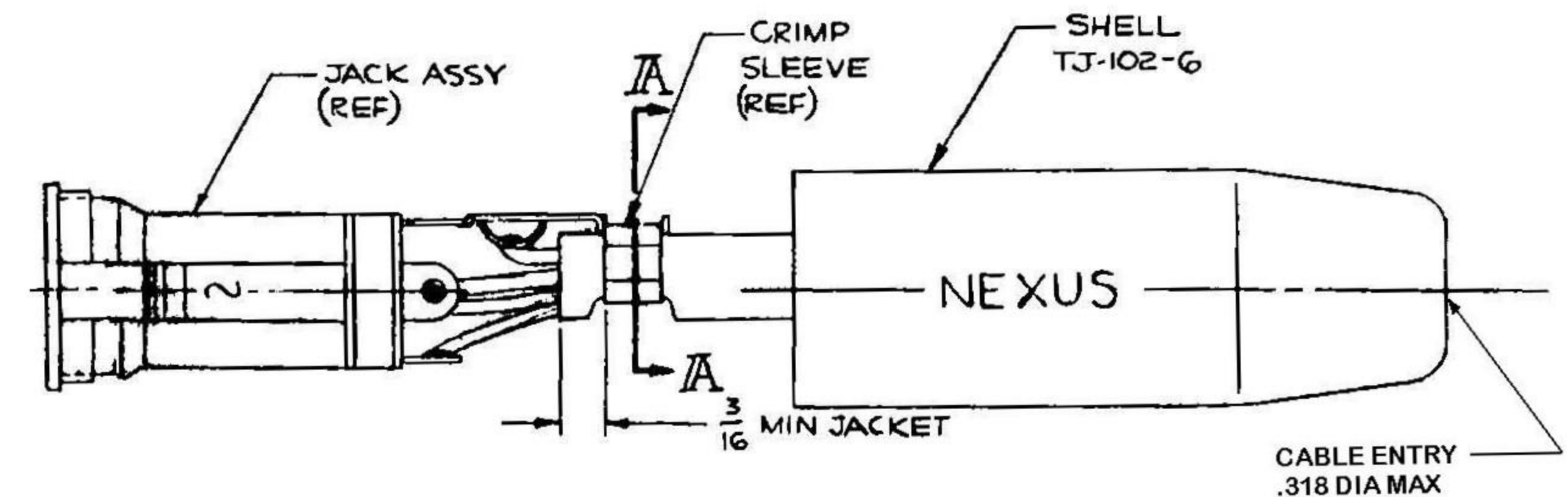

C TJ-102

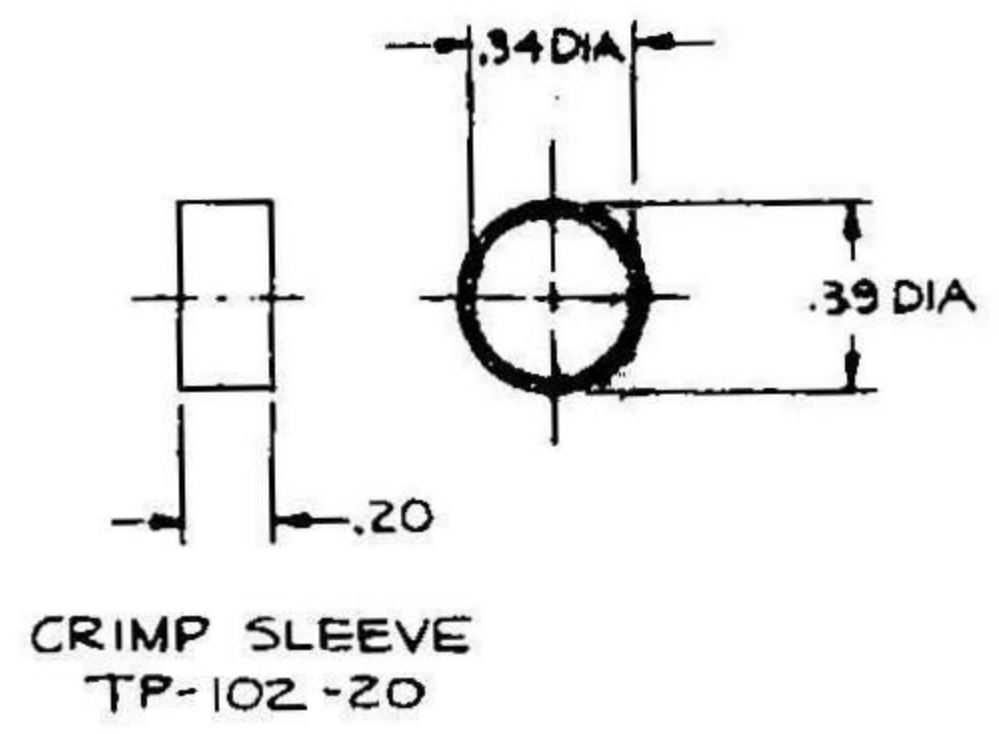
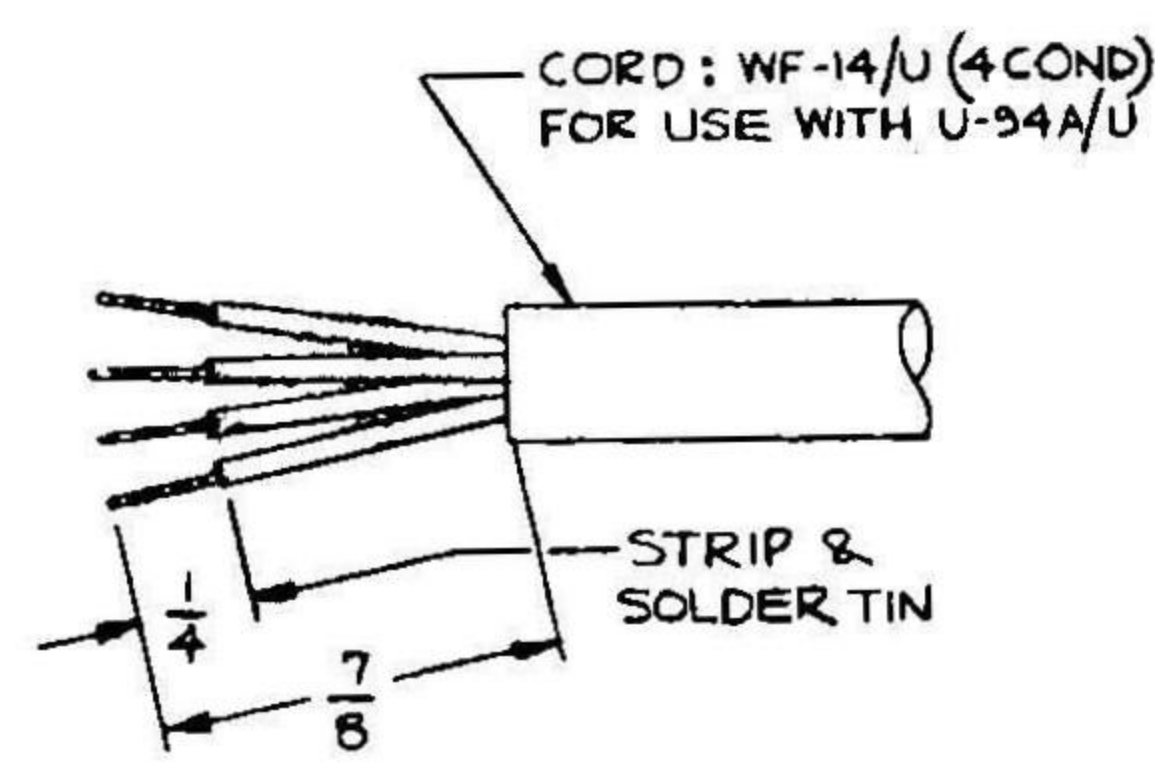

**Australian Representatives**  
**ROJONE, PTY LTD.**  
 Tel: 02 9829 1555  
 E: sales@rojone.com.au  
 www.rojone.com.au

DESIGNED BY IDH	DATE 1/23/87	MATERIAL	
CHECKED BY		FINISH	
APPROVED BY		WEIGHT	SCALE 2:1
UNLESS OTHERWISE SPECIFIED DIMENSIONS ARE IN INCHES TOLERANCES BY FRACTIONS DECIMALS ANGLES		TITLE TELEPHONE JACK	<b>NEXUS</b> STAMFORD, CONN.
REVISION A	DATE 1-26-89	DO NOT SCALE DWG.	SHEET OF C TJ-102