

4

3

2

1

B AJ-165

PART NUMBER	MILITARY PART NO.	CABLE DIA.	BUSHING
AJ-165/13-1	M55116/13-1	.165 ±.010	AP-116-17
AJ-165/13-2	M55116/13-2	.228 ±.010	AP-116-18
AJ-165/13-3	M55116/13-3	.250 ±.010	AP-116-8
AJ-165/13-4	M55116/13-4	.290 ±.010	AP-116-19

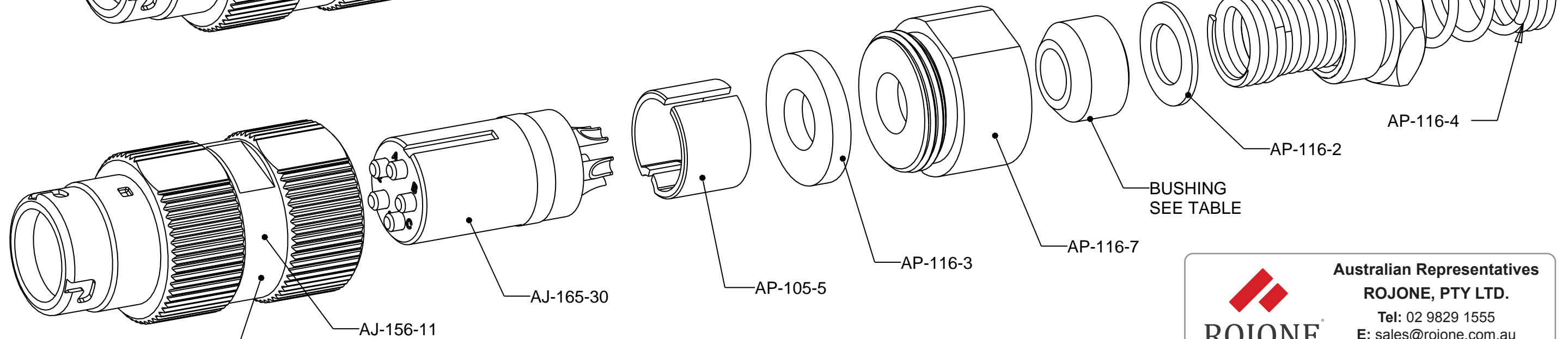
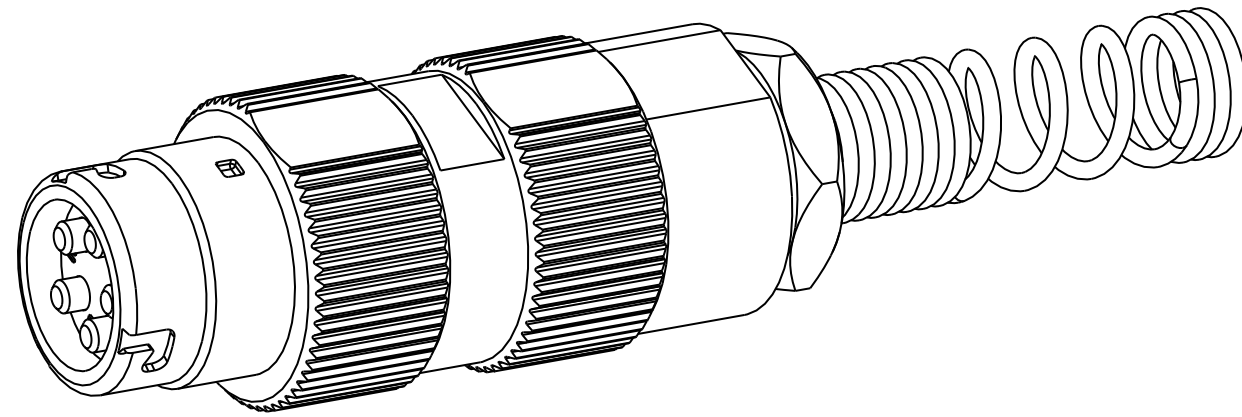

SEE NOTE 2

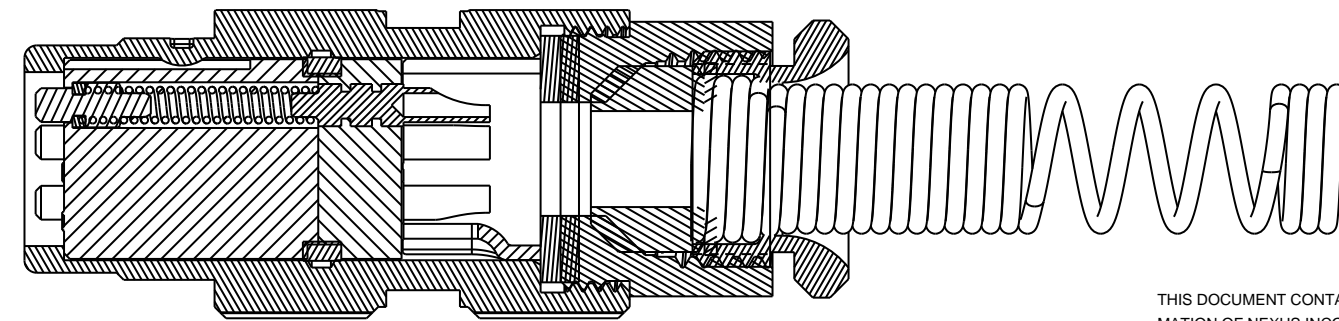
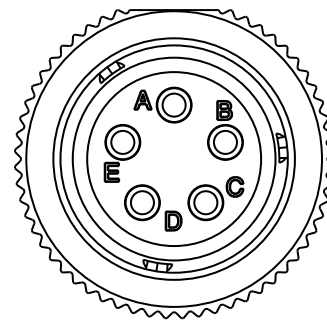

Australian Representatives
ROJONE, PTY LTD.
 Tel: 02 9829 1555
 E: sales@rojone.com.au
 www.rojone.com.au

NOTES;
 1. CONNECTORS ARE QUALIFIED TO MIL-DTL-55116.
 2. MARK MILITARY PART IDENTIFYING NO., MANUFACTURERS NAME AND CAGE CODE LOCATED APPROXIMATELY AS SHOWN.

THIS DOCUMENT CONTAINS PROPRIETARY INFORMATION OF NEXUS, INCORPORATED AND SUCH INFORMATION MAY NOT BE DISCLOSED TO OTHERS FOR ANY PURPOSE OR USED FOR ANY PURPOSE WITHOUT THE WRITTEN CONSENT OF NEXUS.

LET.	REVISION	CN #	DATE	CHK.
A	ADD NOTES AND TABLE AJ-156-11 WAS AP-156-11	037	12/17/09	GPH

DWN.BY	LDE	DATE	13-Jul-09
CHECKED BY		DATE	
APPR.BY		DATE	
UNLESS OTHERWISE SPECIFIED DIMENSIONS ARE IN INCHES TOLERANCES ON			
.XX	.XXX	ANGLES	
	±.003	±.5 °	

MATERIAL	
FINISH	
WEIGHT	SCALE = 2.00 :1
TITLE	
JACK, 5 PIN AUDIO, SOLDER	
DO NOT SCALE DWG.	SHEET 1 OF 1

NEXUS
 STAMFORD, CONN
 SIZE **B** DWG. NO. **AJ-165**