

4

3

2

1

B AJ-155

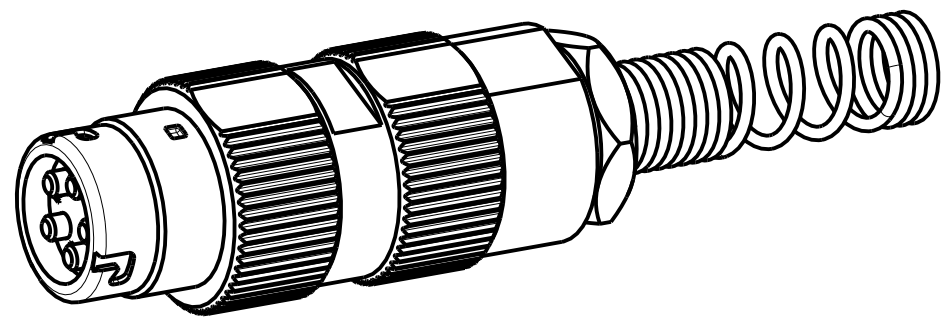
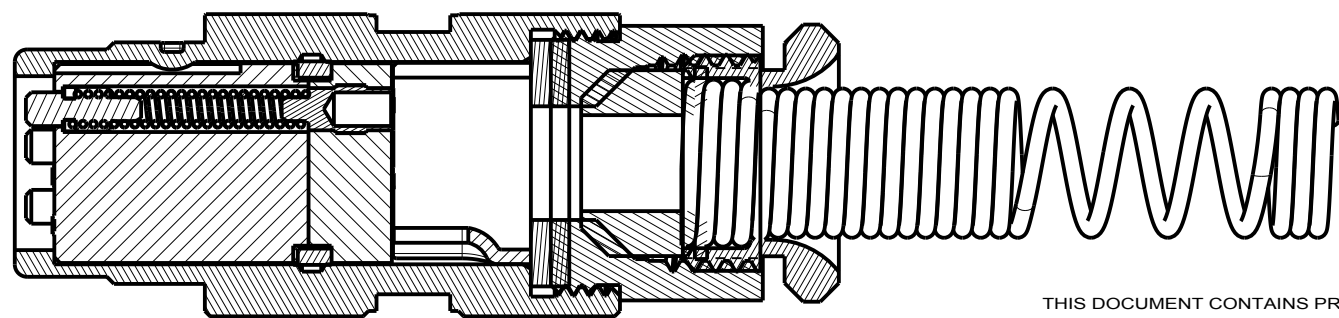
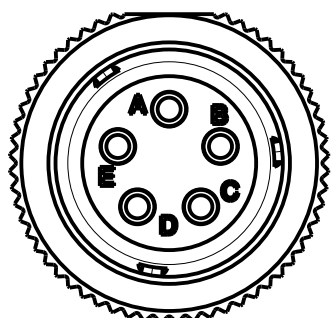
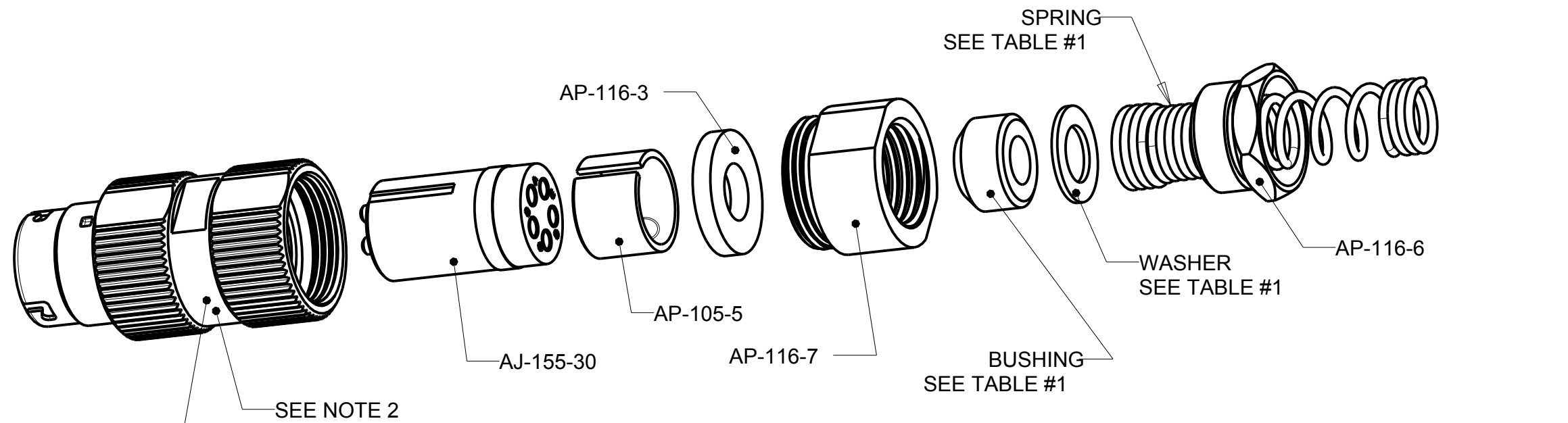

TABLE #1					
PART NUMBER	MILITARY PART #	CABLE DIA.	BUSHING	WASHER	SPRING
AJ-155/11-1	M55116/11-1	$\varnothing .165 \pm .010$	AP-116-17	AP-116-2	AP-116-4
AJ-155/11-2	M55116/11-2	$\varnothing .228 \pm .010$	AP-116-18	AP-116-2	AP-116-4
AJ-155/11-3	M55116/11-3	$\varnothing .250 \pm .010$	AP-116-8	AP-116-2	AP-116-4
AJ-155/11-4	M55116/11-4	$\varnothing .290 \pm .010$	AP-116-19	AP-116-2	AP-116-4
AJ-155/11-5	M55116/11-5	$\varnothing .320 \pm .010$	AP-116-20	AP-116-22	AP-116-21



**ROJONE** PTY. LTD.

Australian Representatives  
**ROJONE, PTY LTD.**  
 Tel: 02 9829 1555  
 E: sales@rojone.com.au  
 www.rojone.com.au

NOTES:  
 1. CONNECTORS ARE QUALIFIED TO MIL-DTL-55116.  
 2. MARK MILITARY PART IDENTIFYING NO., MANUFACTURERS NAME AND CAGE CODE LOCATED APPROXIMATELY AS SHOWN.

THIS DOCUMENT CONTAINS PROPRIETARY INFORMATION OF NEXUS, INCORPORATED AND SUCH INFORMATION MAY NOT BE DISCLOSED TO OTHERS FOR ANY PURPOSE OR USED FOR ANY PURPOSE WITHOUT THE WRITTEN CONSENT OF NEXUS.

LET.	REVISION	CN #	DATE	CHK.
B	ADD NEW P/N	144	9/21 2012	HR
A	ADD NOTES AND TABLE. AJ-156-11 WAS AP-156-11.	036	12/15/09	GPH

DWN.BY	LDE	DATE	13-Jul-09
CHECKED BY		DATE	
APPR.BY		DATE	

UNLESS OTHERWISE SPECIFIED:  
 DIMENSIONS ARE IN INCHES &/OR (mm)  
 TOLERANCES:  
 DECIMAL: .XX[X.X] .XXX[X.XX]  
 $\pm .01[0.3] \pm .003[0.08]$   
 FRACTION: X/X  
 $\pm 1/64$  ANGLES: X  
 $\pm .5^\circ$

MATERIAL	
FINISH	
WEIGHT	SCALE = 2.00 :1
TITLE	
JACK, 5 PIN AUDIO, CRIMP SLEEVE	
DO NOT SCALE DWG.	SHEET 1 OF 1

**NEXUS**  
 STAMFORD, CONN

SIZE **B** DWG. NO. **AJ-155**