

ITEM #	PART #	QTY	DESCRIPTION
1	MAJ-10-65	1	INSERT, RECEPTACLE, 6-COND
2	MAJ-10-67	1	HOUSING JACK
3	MAP-57-01	1	STRAIN RELIEF
4	MAP-50-03	1	WASHER, RUBBER
5	MAP-50-24	1	NUT ADAPTER, ϕ .250
6	AJ-117BR-9	1	BUSHING, ϕ .250
7	AJ-117BR-10	1	WASHER, ϕ .250
8	AJ-117BR-15	1	SPRING, ϕ .250
9	AJ-117BR-11	1	STUD, SHELL ϕ .250

B MAJ-56-30

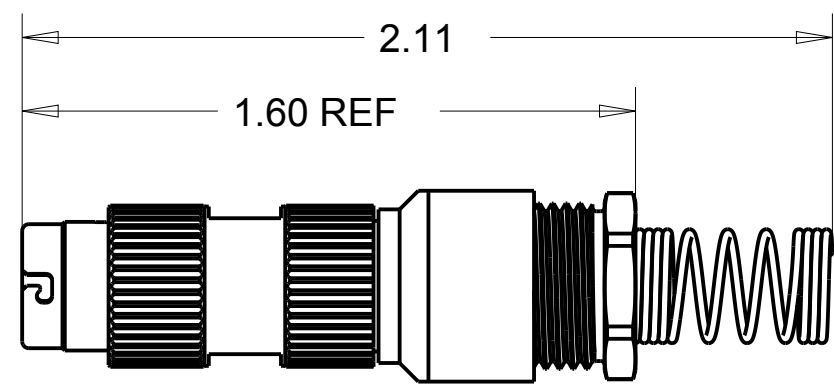
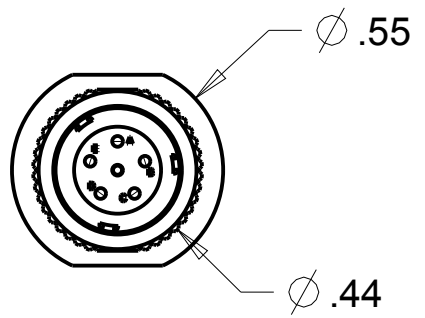
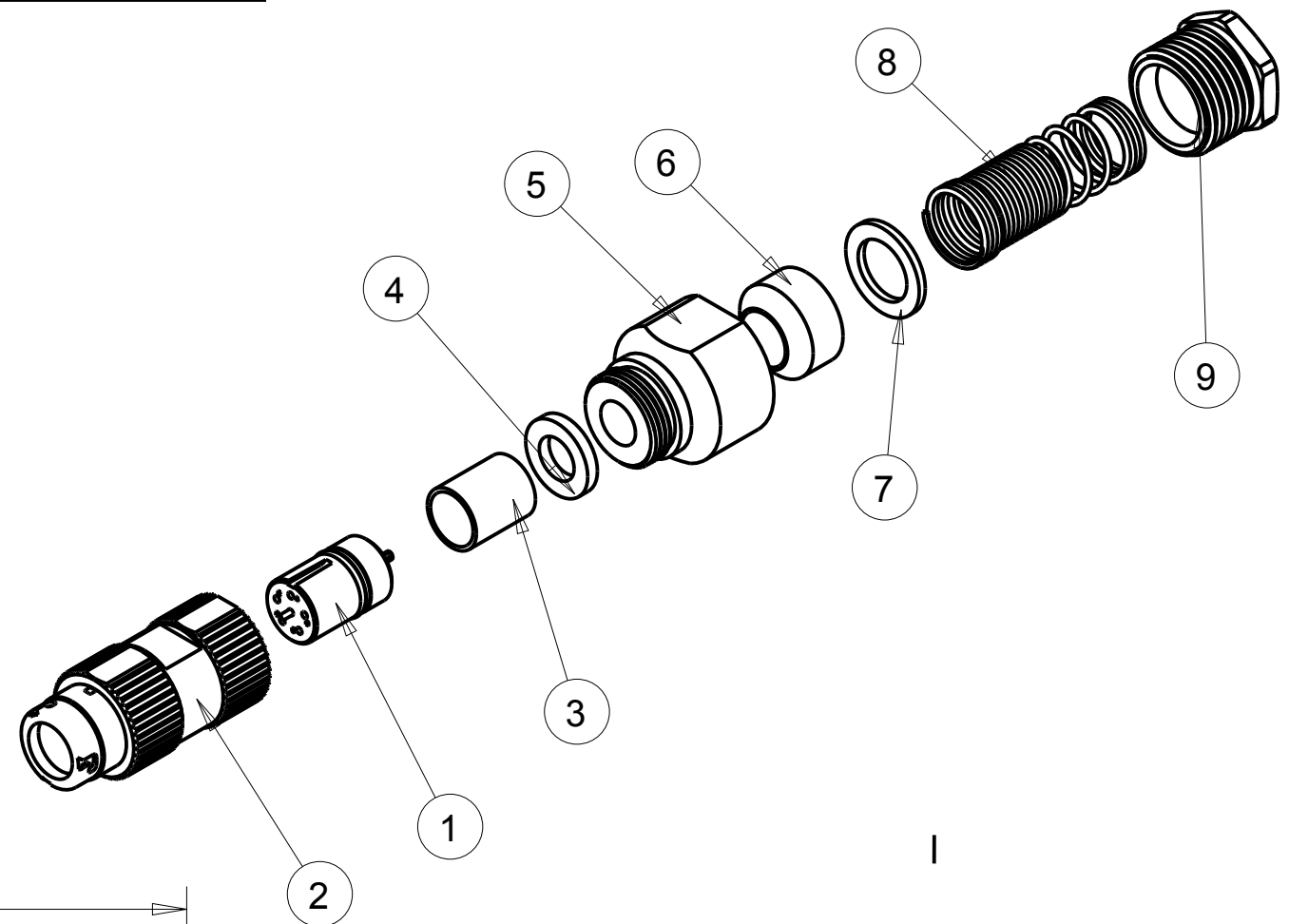

THIS DOCUMENT CONTAINS PROPRIETARY INFORMATION OF NEXUS, INCORPORATED AND SUCH INFORMATION MAY NOT BE DISCLOSED TO OTHERS FOR ANY PURPOSE OR USED FOR ANY PURPOSE WITHOUT THE WRITTEN CONSENT OF NEXUS.

Australian Representatives
ROJONE, PTY LTD.
 Tel: 02 9829 1555
 E: sales@rojone.com.au
 www.rojone.com.au

LET.	REVISION	CN #	DATE	CHK.
C	CHG: MAP-60-06 TO MAP-57-01	152	1/24 2013	HR
B	CHG: MAP-50-05 TO MAP-60-06	146	11/8 2012	HR
A	NEW RELEASE		9/28 2011	HR

DWN.BY	HR	DATE	9/28/11	MATERIAL	
CHECKED BY		DATE		FINISH	
APPR.BY		DATE		WEIGHT	SCALE = 5.00 :1
UNLESS OTHERWISE SPECIFIED: DIMENSIONS ARE IN INCHES &/OR [mm]				TITLE 6- COND JACK ϕ.250 CABLE	
TOLERANCES:					
DECIMAL: .XX[X.X] .XXX[X.XX] \pm .01[0.3] \pm .003[0.08]					
FRACTION: X/X \pm 1/64				DO NOT SCALE DWG. SHEET 1 OF 1	
ANGLES: X \pm .5°				SIZE	DWG. NO.
				B	MAJ-56-30

NEXUS
 STAMFORD, CONN