

ITEM #	PART #	QTY	DESCRIPTION	MATERIAL
1	AP-176-1	1	SHELL ASS'Y	GLASS FILLED NYLON & 303 SS
2	AP-146-6	1	INSERT ASS'Y	DIALLYPHTHALATE, TYPE SDGF & GOLD PLATED BRASS
3	AP-105-5	1	STRAIN RELIEF	NYLON
4	AP-116-3	1	WASHER	RUBBER
5	AP-136-8	1	NUT ADAPTER	ALUMINUM, BLACK CHROME
6	AP-136-6	1	CLAMP SHIELD, OUTER	NICKEL PLATED BRASS
7	AP-136-5	1	CLAMP SHIELD INNER	NICKEL PLATED BRASS
8	SEE TABLE #1	1	BUSHING	RUBBER
9	AP-116-2	1	WASHER	STAINLESS STEEL
10	AP-116-4	1	SPRING	302 STAINLESS STEEL
11	AP-116-6	1	STUD	ANODIZED ALUMINUM ALLOY

TABLE #1		
PART #	CABLE DIA	BUSHING
AP-176-01	∅ .165 ± .010	AP-116-17
AP-176-02	∅ .228 ± .010	AP-116-18
AP-176	∅ .250 ± .010	AP-116-8
AP-176-04	∅ .2905 ± .010	AP-116-19

C AP-176

NOTES:
 1) UNLESS OTHERWISE SPECIFIED, CONNECTOR MEETS ALL GENERAL REQUIREMENTS & SPECIFICATIONS OF MIL-C-55116

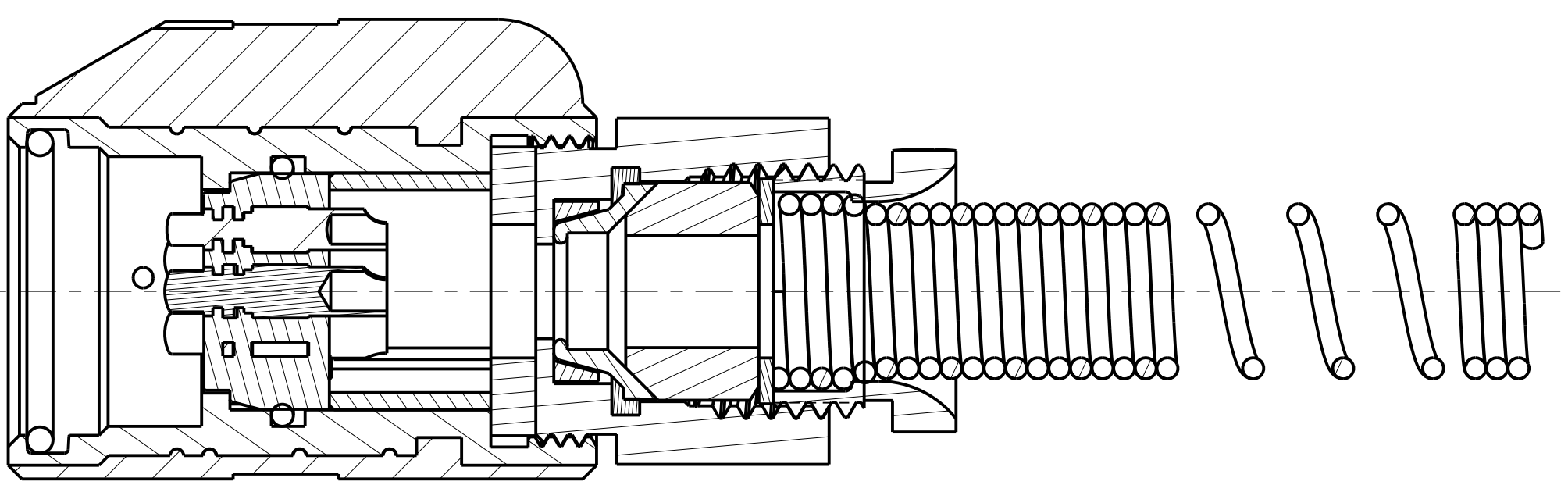
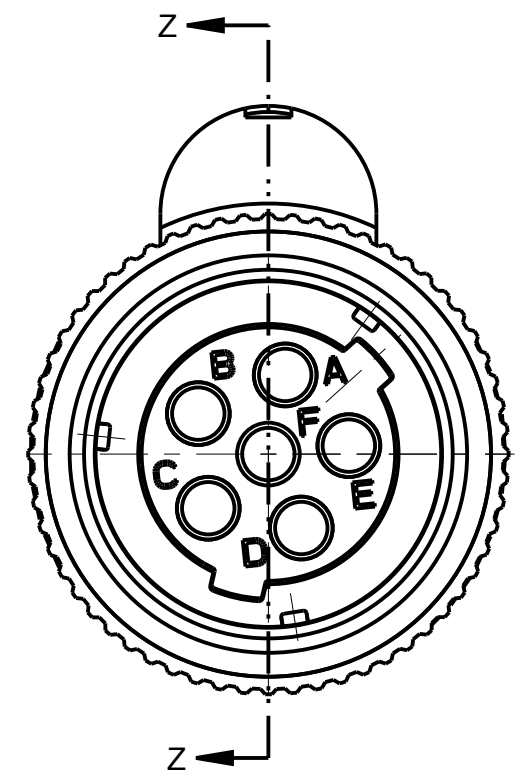
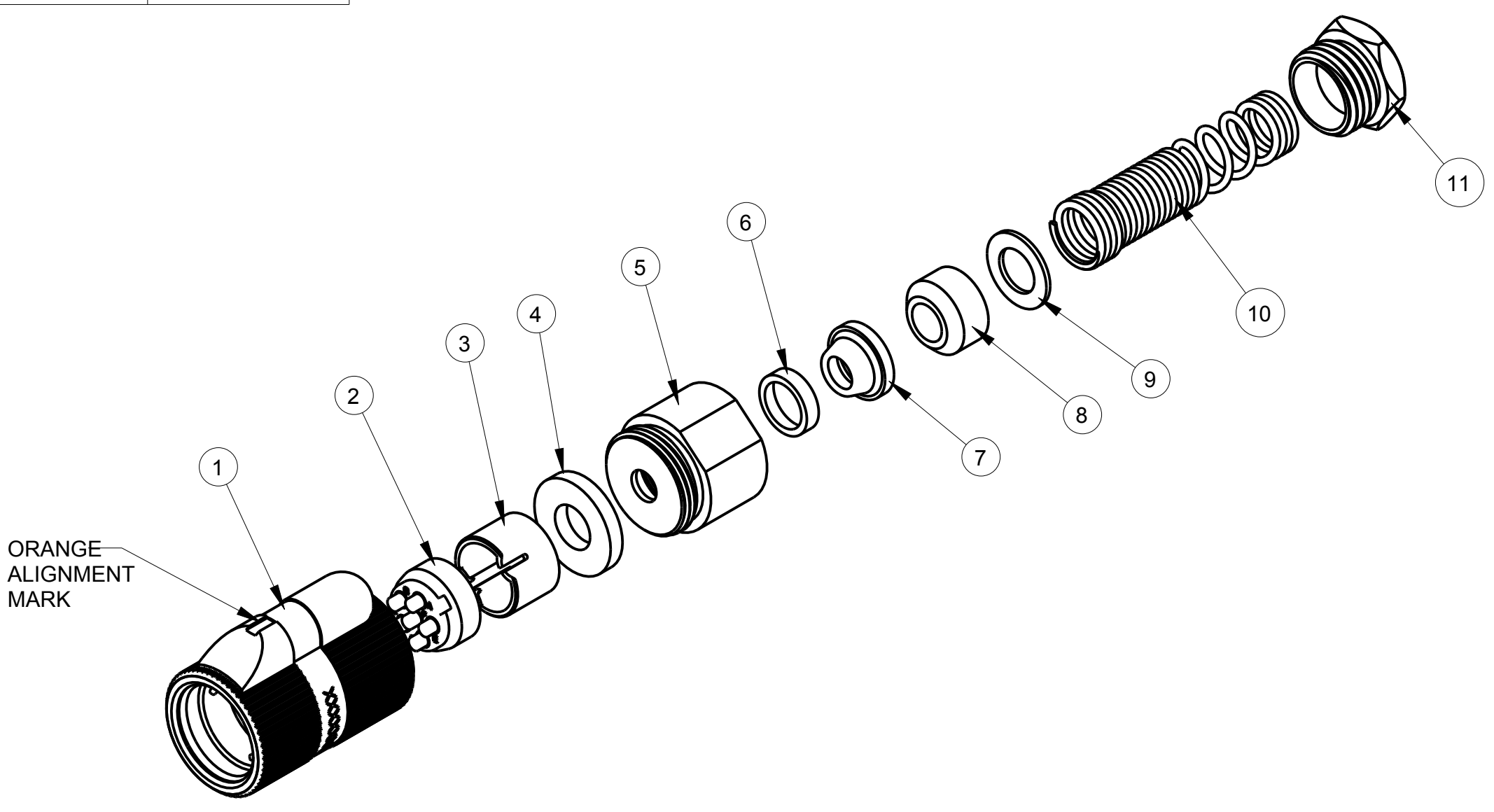

SECTION Z-Z

THIS DOCUMENT CONTAINS PROPRIETARY INFORMATION OF NEXUS, INCORPORATED AND SUCH INFORMATION MAY NOT BE DISCLOSED TO OTHERS FOR ANY PURPOSE OR USED FOR ANY PURPOSE WITHOUT THE WRITTEN CONSENT OF NEXUS.

Australian Representatives
ROJONE, PTY LTD.
 Tel: 02 9829 1555
 E: sales@rojone.com.au
 www.rojone.com.au

D	ADD P/N'S TO P/L	101	2/25 2011	HR	DWN.BY MNF	DATE 5/22/95	MATERIAL	
C	3) IN MAT'L'S REMOVE WITH SS PINS 2) NOTE 2 WAS AP-176-1 1) REMOVE PRESSED IN PIN	045	2/12 2010	GPH	CHECKED BY L SMITH	DATE 5/22/95	FINISH	
B	3)"XUS" WAS "176" 2) AP-175-1 WAS AP-176-XA 1) AP-176-1 WAS AP-176-2	0394	2/24 2000	EWT	APPR.BY L SMITH	DATE 5/22/95	WEIGHT	
A	REVISED & REDRAWN ON CAD	0259	2/24 1997	LS	UNLESS OTHERWISE SPECIFIED DIMENSIONS ARE IN INCHES & OR [mm]		SCALE = 1.00 :1	
LET.	REVISION	CN #	DATE	CHK	TOLERANCES: DECIMAL: ±.XX[X.X] ±.XXX[XX] ±.01[0.3] ±.003[0.08] FRACTION: ±XXX ± 1/64 ANGLES: ±X ° ±5 °		TITLE	
							AUDIO PLUG	NEXUS STAMFORD, CONN
							DO NOT SCALE DWG.	SHEET 1 OF 1
							SIZE C	DWG. NO. AP-176