

ITEM #	PART #	QTY	DESCRIPTION	MATERIAL
1	AP-175-1	1	SHELL ASS'Y	GLASS FILLED NYLON & 303 SS
2	AP-145-6	1	INSERT ASS'Y	DIALLYPHTHALATE, TYPE SDGF & GOLD PLATED BRASS
3	AP-105-5	1	STRAIN RELIEF	NYLON
4	AP-116-3	1	WASHER	RUBBER
5	AP-136-8	1	NUT ADAPTER	ALUMINUM, BLACK CHROME
6	AP-136-6	1	CLAMP SHIELD, OUTER	NICKEL PLATED BRASS
7	AP-136-5	1	CLAMP SHIELD INNER	NICKEL PLATED BRASS
8	AP-116-8	1	BUSHING	RUBBER
9	AP-116-2	1	WASHER	STAINLESS STEEL
10	AP-116-4	1	SPRING	302 STAINLESS STEEL
11	AP-116-6	1	STUD	ANODIZED ALUMINUM ALLOY

C AP-175

NOTES:  
 1) UNLESS OTHERWISE SPECIFIED, CONNECTOR MEETS ALL GENERAL REQUIREMENTS & SPECIFICATIONS OF MIL-C-55116

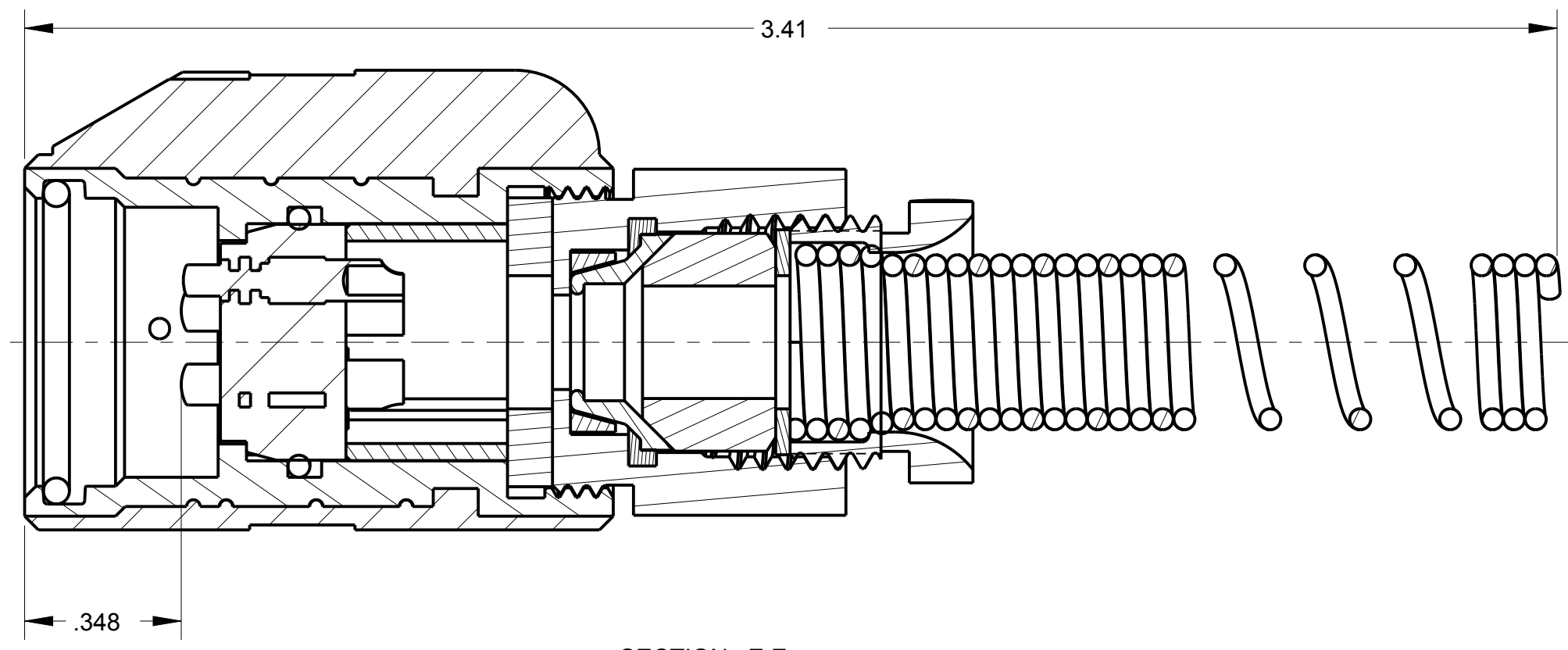
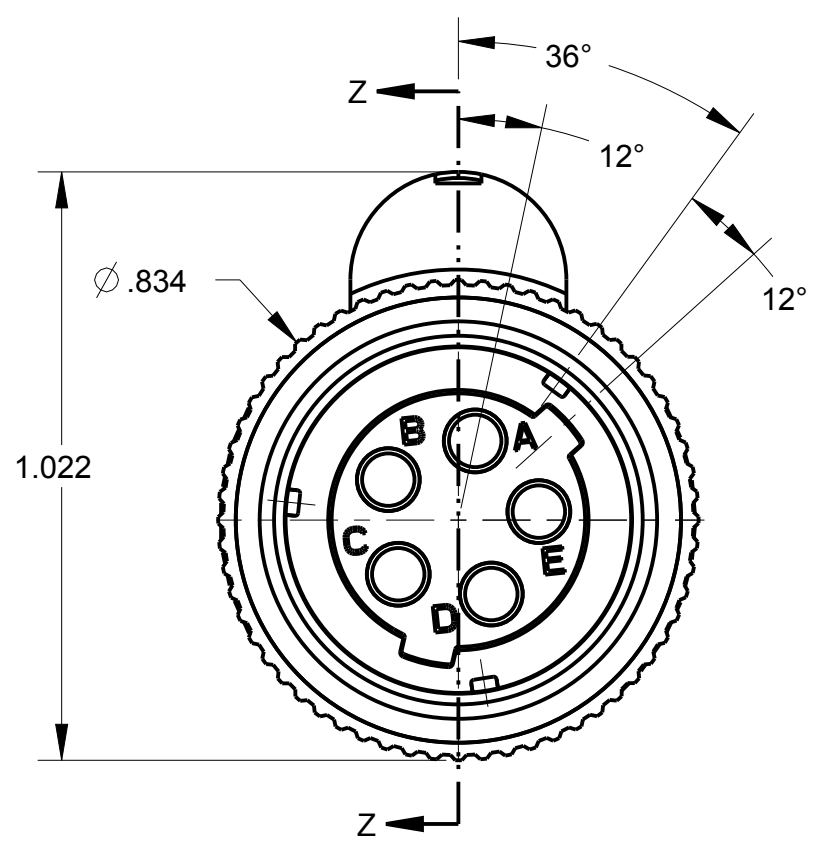
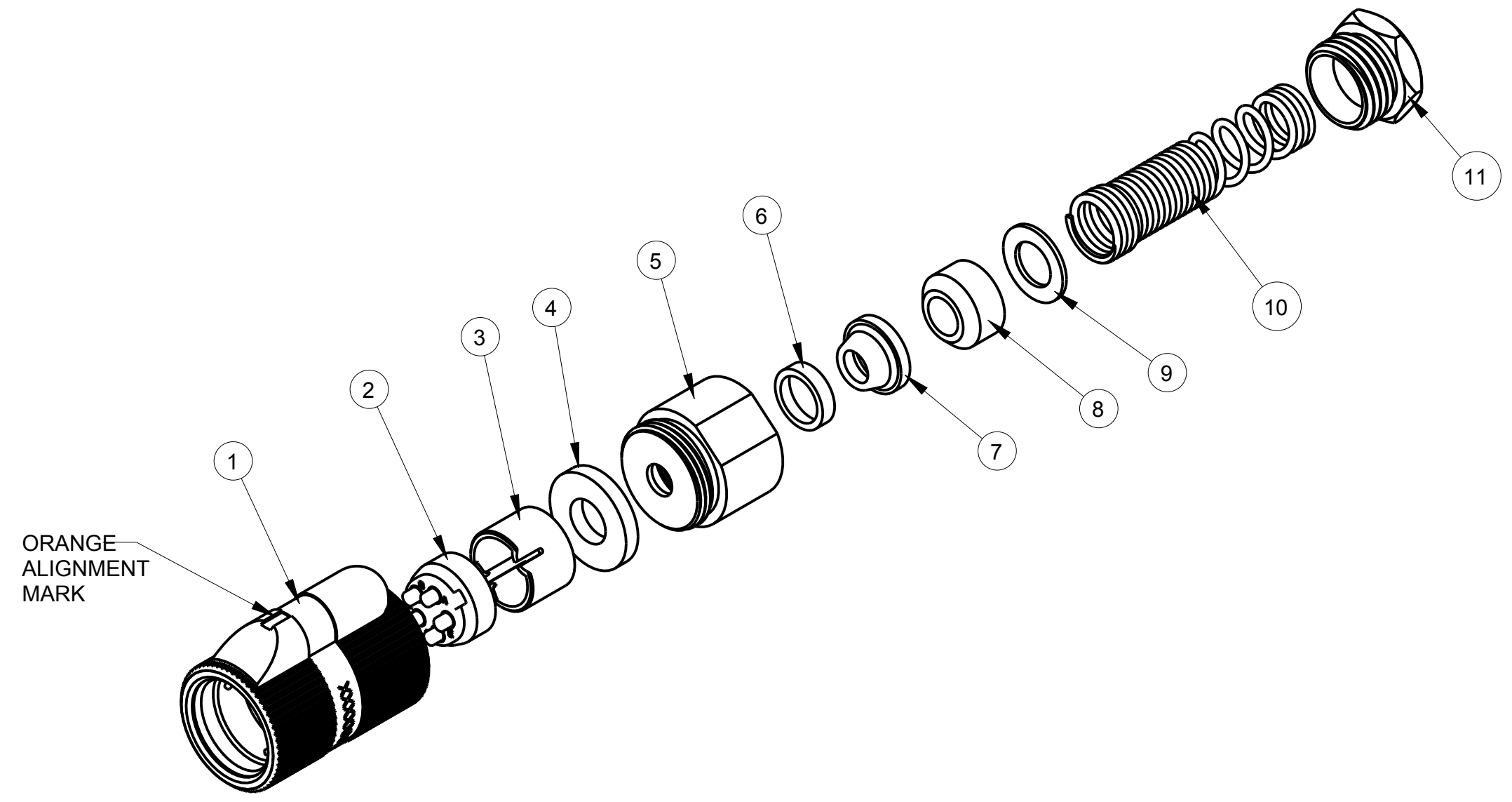

SECTION Z-Z

THIS DOCUMENT CONTAINS PROPRIETARY INFORMATION OF NEXUS, INCORPORATED AND SUCH INFORMATION MAY NOT BE DISCLOSED TO OTHERS FOR ANY PURPOSE OR USED FOR ANY PURPOSE WITHOUT THE WRITTEN CONSENT OF NEXUS.

**Australian Representatives**  
**ROJONE, PTY LTD.**  
 Tel: 02 9829 1555  
 E: sales@rojone.com.au  
 www.rojone.com.au

LET.	REVISION	CN #	DATE	CHK
B	ADD P/N'S TO P/L	101	2/25 2011	HR
A	REVISED & REDRAWN ON CAD	0259	2/24 1997	LS

DWN.BY	MNF	DATE	2/6/97
CHECKED BY	L SMITH	DATE	9/10/97
APPR.BY	L SMITH	DATE	9/10/97

MATERIAL	
FINISH	
WEIGHT	SCALE = 1.00 :1
TITLE	
AUDIO PLUG SHIELDED	
DO NOT SCALE DWG.	SHEET 1 OF 1

**NEXUS**  
 STAMFORD, CONN

SIZE DWG. NO.  
**C** AP-175

UNLESS OTHERWISE SPECIFIED DIMENSIONS ARE IN INCHES & OR [mm]  
 TOLERANCES:  
 DECIMAL: ±.XX[X.X] ±.XXX[XX.XX]  
 ±.01[0.3] ±.003[0.08]  
 FRACTION: ±XXX ± 1/64 ANGLES: ±X ° ±5 °