

**HN / HN2 / BR2 / BD2 /
High voltage (BNC HT / SHV / MQ HT / THT 20) series**

R176 / R616 / R605 / R606 / R316 / R317 / R321 / R331

RADIALL 
The next conneXion

	Pages
HN	
Interface	15-4
Plugs	15-4
Jack	15-5
Receptacle	15-5
Adapter	15-5
Caps	15-6
Panel drilling	15-6
HN2	
Interface	15-6
Characteristics	15-7
Plug	15-7
Receptacle	15-7
Adapter	15-7
Panel drilling	15-7
BR2	
Interface	15-8
Characteristics	15-8
Plugs	15-9
Jacks	15-9
Receptacles	15-10
Caps	15-10
Gasket	15-11
Panel drilling	15-11
BD2	
Interface	15-12
Plug	15-12
Receptacle	15-12
Panel drilling	15-12
HIGH VOLTAGE	
Introduction	15-13
BNC HT	
Characteristics	15-13
Plugs	15-14
Jacks	15-14
Receptacles	15-14
Adapters	15-15
Cap	15-15
Gasket	15-15
SHV	
Characteristics	15-16
Plugs	15-17
Jacks	15-17
Receptacles	15-18
Adapter	15-18
Miniquick HT	
Characteristics	15-18
Plugs	15-19
Jacks	15-19
Receptacles	15-19
THT 20	
Characteristics	15-20
Plugs	15-21
Receptacles	15-21
Cap	15-21
Panel drilling	15-22

STRAIGHT JACK CLAMP TYPE

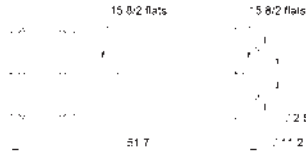

Fig. 1

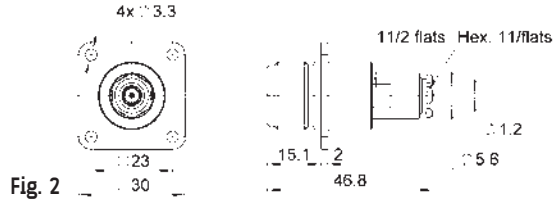

Fig. 2

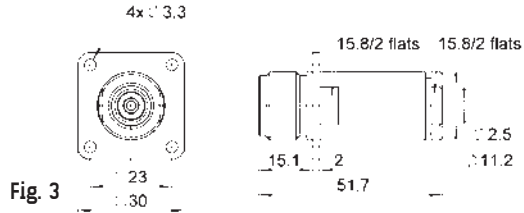
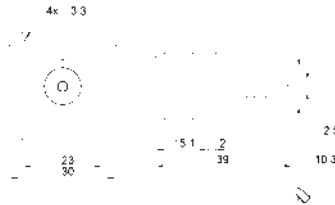

Fig. 3

Cable group	Cable group dia.	Part number	Fig	Panel drilling	Note
RG213/RG393/RG214	10+11/50	R176 218 000	1		
RG58/RG141/RG142/RG223/RG400	5/50/S+D	R176 256 000	2	P02	square flange
RG213/RG393/RG214	10+11/50	R176 268 000	3		

FLANGE RECEPTACLE



Part number	Panel drilling	Note
R176 404 000	P02	square flange - solder pot

IN SERIES ADAPTERS

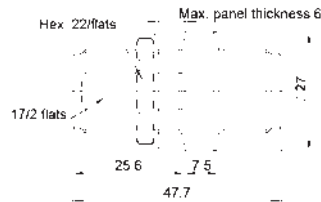

Fig. 1

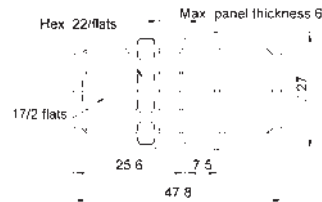

Fig. 2

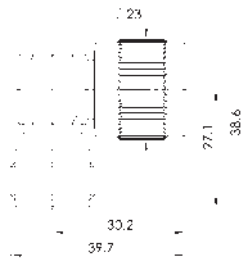

Fig. 3

Part number	Fig	Panel drilling	Note
R176 754 000	1	P01	bulkhead female-female - splashproof panel seal
R176 754 150	2		bulkhead female-female - splashproof panel seal - ceramic insulator
R176 770 000	3		right angle - male-female

To download data sheets and assembly instructions, visit www.radiall.com & enter the part number in the Search box.
Bold part numbers represent products typically in stock & available for immediate shipment.
 See page 8 and 9 for packaging information.

CAPS

CAPS

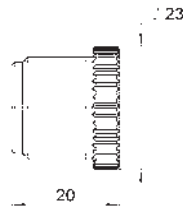

Fig. 1

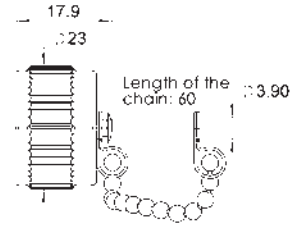

Fig. 2

Part number	Fig	Note
R176 830 010	1	protective cap
R176 811 000	2	protective cap with chain

PANEL DRILLING

P01



	mm	
	Maxi	mini
A	19.3	19.2
B	17.3	17.2

P02

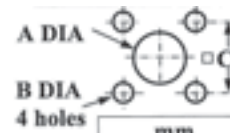

	mm	
	Maxi	mini
A	19.5	19.4
B	3.5	3.4
C	23.1	23

INTERFACE HN2

PLUG

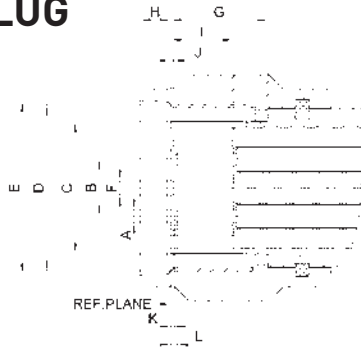

JACK

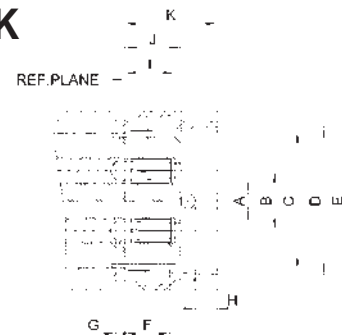

Letter	mm		inch	
	min.	max.	min.	max.
A DIA	1.31	1.37	0.052	0.054
B	6.3	6.4	0.248	0.252
C DIA	15.0	15.15	0.591	0.596
D	3/4X20 UNEF 2B		3/4X20 UNEF 2B	
E DIA	19.4	19.6	0.764	0.772
F	1.57	1.62	0.062	0.064
G	11	11.2	0.433	0.441
H	3.0	3.75	0.118	0.148
I	6.2	6.45	0.244	0.254
J	-0.55	0.5	-0.022	0.02
K	-0.28	0.725	0.011	0.029
L	0.125	1.31	0.005	0.052

Letter	mm		inch	
	min.	max.	min.	max.
A DIA	1.47	1.55	0.058	0.061
B DIA	6.3	6.4	0.248	0.252
C DIA	14.75	14.85	0.581	0.585
D DIA	15.65	15.85	0.616	0.624
E	3/4X20 UNEF 2A		3/4X20 UNEF 2A	
F	4.65	5.8	0.183	0.228
G	0.75	1.75	0.03	0.069
H	2.275	2.46	0.09	0.097
I	4.21	4.51	0.166	0.178
J	5.95	6.3	0.234	0.248
K	9.81	9.91	0.386	0.39

CHARACTERISTICS

ELECTRICAL CHARACTERISTICS

Frequency range	DC to 500 MHz
Impedance	95Ω
Test voltage at sea level	500 V peak
Insulation resistance	> 5000 MΩ

MECHANICAL CHARACTERISTICS

Life	500 matings
Vibration	1/2 sinusoidal (severity 100 A)

ENVIRONMENTAL

Temperature range	-50°C + 125°C
Salt spray	48 Hrs

MATERIALS

Contacts and interfaces	Heat treated beryllium copper
Other pieces	Brass
Insulator	Rexolite
Gasket	Silicone rubber

PLUG, RECEPTACLE AND ADAPTER

STRAIGHT PLUG CLAMP TYPE

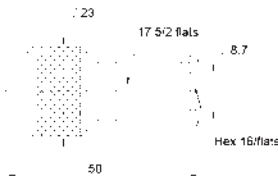

Cable group dia.	Part number	Note
twinaxial 8	R616 008 000	Belden P/N Y 15662 IBM P/N 7362211

BULKHEAD RECEPTACLE, SOLDER POT

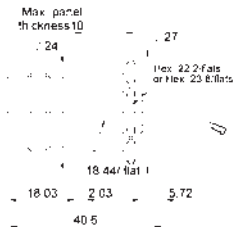

Part number	Panel drilling
R616 549 000	P01

IN SERIES ADAPTER

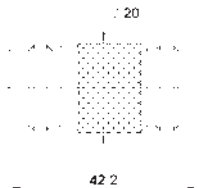

Part number	Note
R616 705 000	female - female

P01

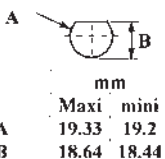

PANEL DRILLING

To download data sheets and assembly instructions, visit www.radiall.com & enter the part number in the Search box.
Bold part numbers represent products typically in stock & available for immediate shipment.
 See page 8 and 9 for packaging information.

INTERFACE

PLUG

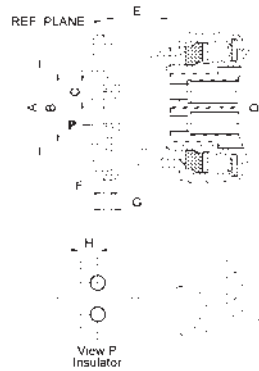

JACK

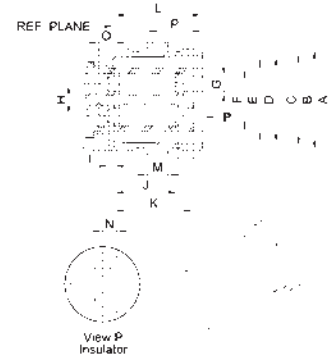

Letter	mm		inch	
	min.	max.	min.	max.
A DIA	9.78	9.91	.385	.390
B DIA	6.70	6.77	.264	.267
C DIA	1.31	1.36	.052	.054
D	2.95	3.05	.116	.120
E	7.6	7.9	.299	.311
F	-0.05	0.15	.002	.006
G	0.85	1.55	.033	.061
H	1.55	1.65	.061	.065

Letter	mm		inch	
	min.	max.	min.	max.
A DIA	10.93	11.09	.430	.437
B DIA	9.60	9.70	.378	.382
C DIA	8.79	9.04	.346	.356
D DIA	8.31	8.46	.327	.333
E DIA	8.09	8.15	.319	.321
F DIA	5.9	6.0	.232	.236
G DIA	1.4	1.45	.055	.057
H	2.95	3.05	.116	.120
I	-0.1	0.8	-.004	.031
J	5.3	5.7	.209	.224
K	7.05	7.35	.278	.289
L	8.36	8.46	.327	.335
M	1.91	2.06	.075	.081
N	1.45	1.55	.057	.061
O	0.35	0.85	.014	.033

CHARACTERISTICS

Bayonet lock coupling with polarisation

ELECTRICAL AND ENVIRONMENTAL CHARACTERISTICS

Dielectric withstanding voltage	between pins between pins and body	1500 volts RMS, 50 Hz
Maximum intensity	3.5 Amp	
Insulation resistance	between pins between pins and body	> 10 ⁵ MΩ
Contact resistance	< 1 mΩ at 1 Amp	
Capacity at 1 MHz	between pins between pins and body	< 1.3 pF < 3.2 pF
Frequency range	DC - 0.5 GHz	
Temperature range	-40 +100° C	

MATERIALS

All metal parts under stress	Beryllium copper
Other metal parts	Brass
Insulators	Polyamide and diallyphtalate
Gaskets	Neoprene

STRAIGHT PLUGS FOR ARMOUR TWINAXIAL CABLE

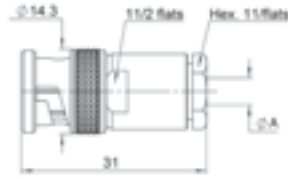

Cable group dia	Part number	Dimensions (mm) A
twinaxial 4	R605 004 000	4.6
twinaxial 5	R605 005 000	5.6
twinaxial 6	R605 006 000	6.6

RIGHT ANGLE PLUG

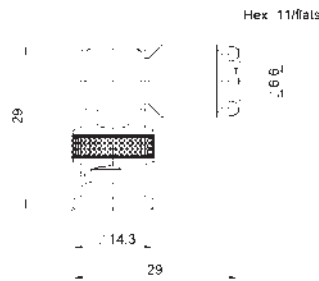

Cable group dia	Part number
twinaxial 6	R605 156 000

STRAIGHT JACKS

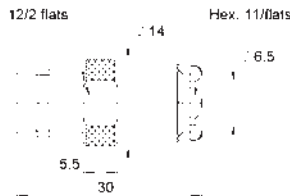

Fig. 1

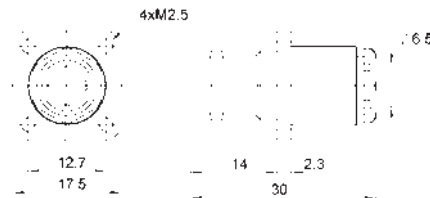

Fig. 2

Cable group dia	Part number	Fig	Panel drilling	Note
twinaxial 6	R605 206 000	1	P01	square flange
	R605 256 000	2		

To download data sheets and assembly instructions, visit www.radiall.com & enter the part number in the Search box. **Bold** part numbers represent products typically in stock & available for immediate shipment. See page 8 and 9 for packaging information.

RECEPTACLES AND CAPS

RECEPTACLES

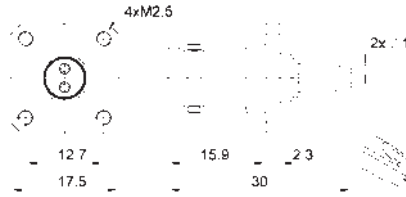

Fig. 1

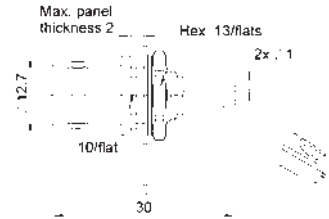

Fig. 2

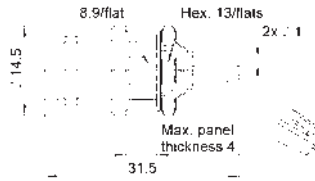

Fig. 3

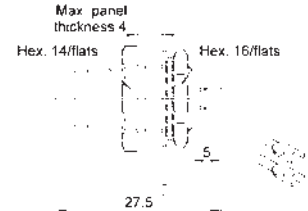
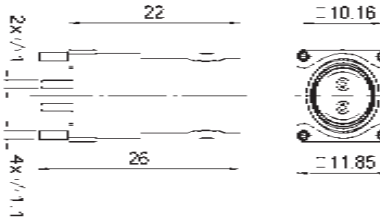

Fig. 4

Part number	Fig	Panel drilling	Note
R605 400 000	1	P02	Square flange
R605 550 000	2	P04	Rear fixing
R605 550 020			Front mounting
R605 600 000	3	P05	Waterproof
R605 610 000	4	P06	Hermetically sealed glass - seal

PCB RECEPTACLES



Part number	Panel drilling
R605 440 000	P03

CAPS



Fig. 1

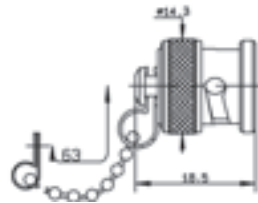

Fig. 2

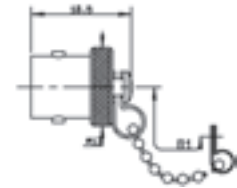
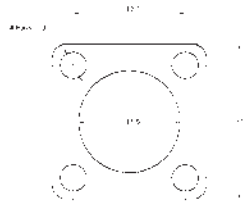

Fig. 3

Part number	Fig.	Note
R141 802 000	1	Male
R141 812 000	2	Male with chain
R141 842 000	3	Female with chain

GASKET



Part number
R280 503 000

PANEL DRILLING

P01

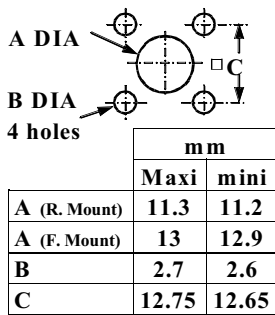

P02

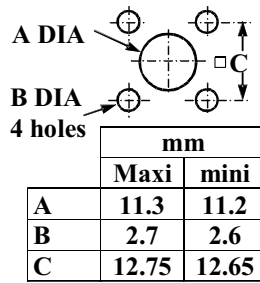

P03

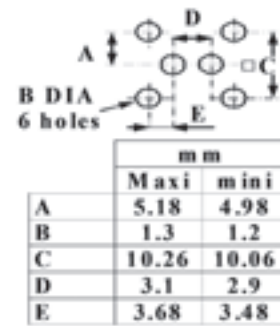

P04

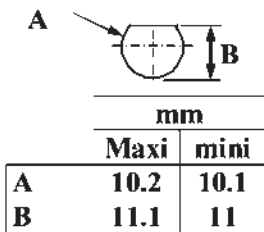

P05

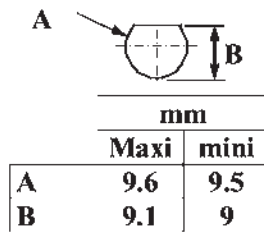

P06

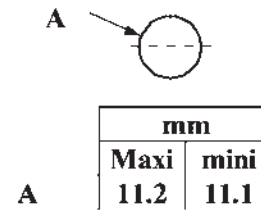

INTERFACE

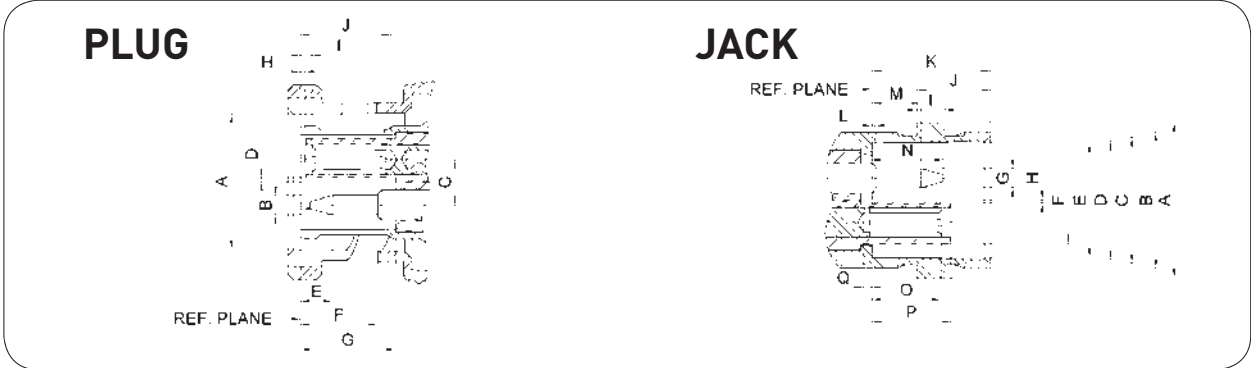

Letter	mm		inch	
	min.	max.	min.	max.
A DIA	9.78	9.91	.385	.390
B DIA	1.32	1.37	.052	.054
C	3.05	3.15	.120	.124
D	0.05	---	.002	---
E	1.95	2.95	.077	.116
F	6.45	6.95	.254	.274
G	5.35	6.15	.211	.242
H	0.15	---	.006	---
I	0.7	1.3	.028	.051
J	5.9	7	.232	.276

Letter	mm		inch	
	min.	max.	min.	max.
A DIA	10.93	11.09	.430	.437
B DIA	9.60	9.70	.378	.382
C DIA	8.79	9.04	.346	.356
D DIA	8.31	8.46	.327	.333
E DIA	8.09	8.15	.319	.321
F DIA	---	6.25	---	.246
G DIA	1.32	1.37	.052	.054
H	0.05	---	.002	---
I	1.91	2.07	.075	.081
J	5.18	5.28	.204	.208
K	8.31	8.51	.327	.335
L	-0.05	0.55	-.002	.022
M	2.95	3.95	.116	.156
N	4.55	5.55	.179	.219
O	4.6	5.2	.181	.206
P	5.45	5.75	.215	.226
Q	0.495	0.605	.019	.024

PLUG AND RECEPTACLE

STRAIGHT PLUG

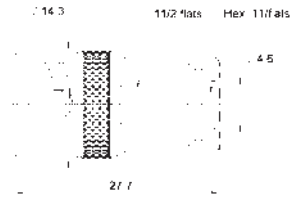

Cable group dia	Part number
4 mm	R606 004 000

BULKHEAD RECEPTACLE

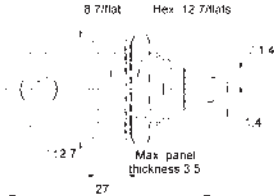

Part number	Panel drilling
R606 550 000	P01

PANEL DRILLING

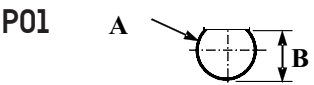

	mm	
	Maxi	mini
A	9.7	9.6
B	8.9	8.8

This catalogue features 4 series of high voltage coaxial connectors, able to withstanding continuous voltages up to 20 000 V.

TEST VOLTAGES

The test voltages quoted in this catalogue are indicative only. They correspond to those made under normal atmospheric conditions during a test period of 1 minute as specified in the French standard NF EN 60068 - 1.

OPERATING VOLTAGES

The operating voltage is chosen under the responsibility of users, depending on the conditions in which the connectors will be used (environmental, safety factor...). The indicated cables are recommended for the mechanical and dimensional suitability with our connectors. As to the electrical characteristics of the cables and in particularly the maximum voltage capacity, it is necessary to conform with the recommendation of the cable manufacturer.

CHARACTERISTICS BNC HT

The connectors of this series are not intermateable with those of the BNC and SHV series.

ELECTRICAL CHARACTERISTICS

Frequency range	DC - 2 GHz	
Impedance	50Ω	
VSWR (plug and jack)	1.20 + 0.2 F (GHz)	
Test voltage	unmated (male) connectors	6 000 V D.C.
	(female)	8 000 V D.C.
	mated pair	10 000 V D.C.
Current rating	10 A	

MECHANICAL AND ENVIRONMENTAL CHARACTERISTICS

Mating cycles	500
Vibration	20 g - 2 000 Hz
Shock	50 g
Salt spray	48 H
Temperature range	- 55°C + 155°C - 40°C + 70°C (with polyethylene insulator)

MATERIALS AND PLATING

Components	Materials	Platings
Body	Brass	Nickel
Center contact	Brass / Beryllium copper	Silver
Other metal parts	Brass or Beryllium copper	Nickel
Insulator	PTFE / Polyethylene	
Gasket	Silicone rubber	

All dimensions are given in mm

PLUGS, JACKS AND RECEPTACLES

STRAIGHT PLUGS FOR FLEXIBLE CABLES

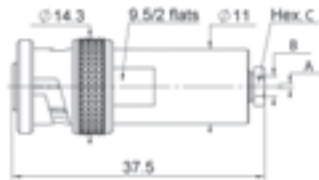

Fig. 1

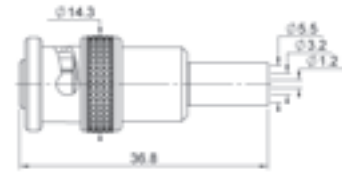

Fig. 2

Cable group	Cable group dia.	Part number	Fig.	Dimensions			Note
				A dia.	B dia.	Hex. C	
RG174/RG316/RD316/RG179/RD179	2.6/50+75/S + D	R316 004 000	1	0.6	3	5/flats	Clamp type
RG58/RG141/RG142/RG223/RG400	5/50/S + D	R316 007 000	1	1.2	5.6	9.5/flats	
RG59/RG62	6/75/S	R316 011 000	1	1.2	6.5	9.5/flats	
RG58/RG141	5/50/S	R316 072 000	2				Crimp type

STRAIGHT JACKS CLAMP TYPE FOR FLEXIBLE CABLES

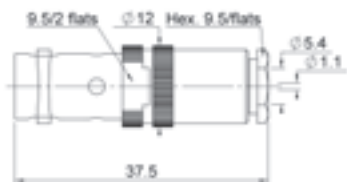

Fig. 1

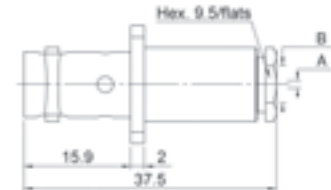

Fig. 2

Cable group	Cable group dia.	Part number	Fig.	Dimensions		Panel Drilling
				A dia.	B dia.	
RG58/RG141/RG142/RG223/RG400	5/50/S + D	R316 207 000	1			P01
		R316 257 000	2	1.1	5.4	
RG59/RG62	6/75/S	R316 261 000	2	1.1	6.5	

RECEPTACLES

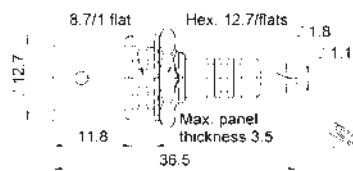

Fig. 1

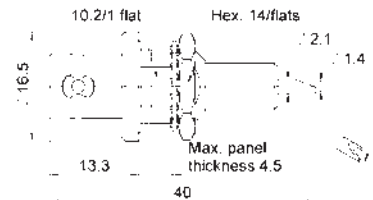

Fig. 2

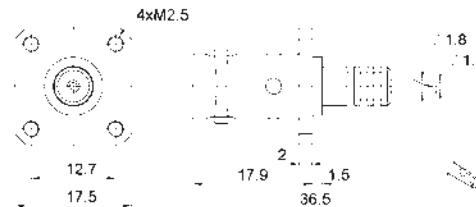

Fig. 3

Part number	Fig.	Panel Drilling	Note
R316 553 000	1	P02	Bulkhead
R316 603 000	2	P03	Bulkhead panel seal
R316 405 000	3	P01	Square flange mounting

IN SERIES ADAPTERS

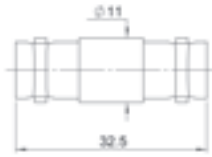

Fig. 1

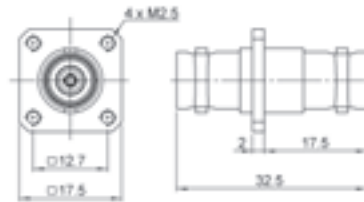

Fig. 2

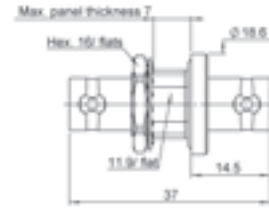

Fig. 3

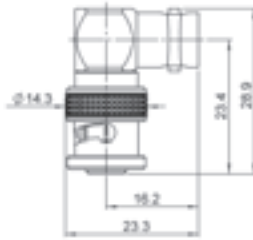

Fig. 4

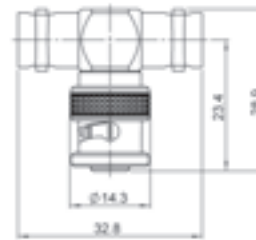
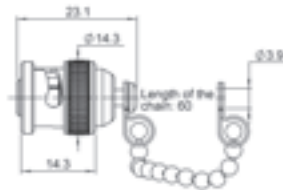

Fig. 5

Part number	Fig.	Panel Drilling	Note
R316 704 000	1		Straight female - female
R316 714 000	2	P01	Square flange female - female
R316 754 000	3	P04	Straight bulkhead female - female with panel seal
R316 770 000	4		Right angle male - female polyethylene insulator
R316 780 000	5		Tee female female - male polyethylene insulator

CAP



Part number
R316 812 000

GASKET

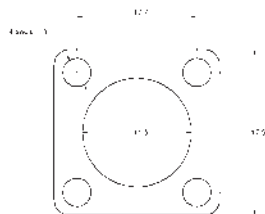

Part number
R280 503 000

CHARACTERISTICS

These safe high voltage connectors meet all requirements of the NIM Standard (Nuclear Instrumentation Module) Specification ND 545 Amendment A. Both the pin and socket contacts are securely recessed inside the insulation to prevent the danger of electrical shock when live unmated connectors are handled.

They are particularly recommended for impulse circuits of linear accelerators as well as in military, nuclear and medical electronics.

These connectors are not intermateable with those of the BNC and BNC.HT series.

ELECTRICAL CHARACTERISTICS

Frequency range		DC - 2 GHz
Impedance		50Ω
VSWR (plug and jack)		< 1.20 + 0.3 F (GHz)
Contact resistance	center contact	< 2.1 mΩ
	outer contact	< 1.5 mΩ
Test voltage	unmated connectors	10 000 V D.C. - 1 mΩ
	mated pair	12 000 V D.C. - 1 mΩ
Current rating		10 A

MECHANICAL AND ENVIRONMENTAL CHARACTERISTICS

Temperature range		- 65°C + 165°C
Mating cycles		500
Vibration		10 g - 500 Hz to MIL-STD-202, method 204, condition A
Shock		to MIL-STD-202, method 213 B, condition A
Salt spray		to MIL-STD-202, method 101, condition B-48 H
Contact to cable retention force		> 27 N
Coupling nut retention force		> 450 N
Cable retention		> 180 N

MATERIALS AND PLATING

Components	Materials	Plating
Body	Brass	Nickel
Center contact	Brass / Beryllium copper	Gold
Other metal part	Brass / Beryllium copper	Nickel
Insulator	PTFE	
Gasket	Silicone rubber	

All dimensions are given in mm

STRAIGHT PLUGS FOR FLEXIBLE CABLES

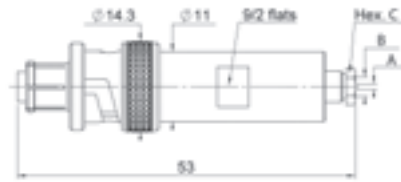

Fig. 1

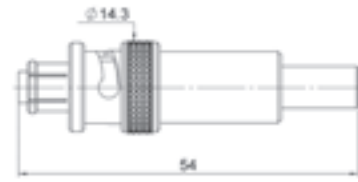

Fig. 2

Cable group	Cable group dia.	Part number	Fig.	Dimensions			Captive center contact	Note
				A dia.	B dia.	Hex. C		
RG58/RG141/RG142 RG223/RG400	5/50/S + D	R317 005 000	1	1.05	5.6	9.5/flats	Yes	Clamp type
RG58/RG141	5/50/S	R317 072 000	2					Crimp type
RG59/RG62	6/75/S	R317 074 000						

STRAIGHT JACKS FOR FLEXIBLE CABLES

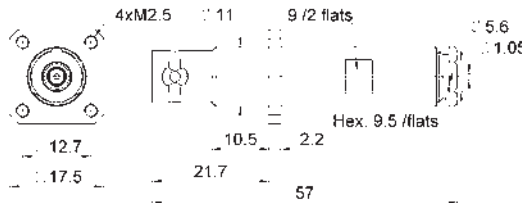
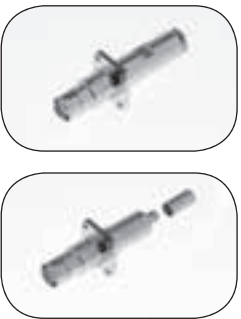

Fig. 1

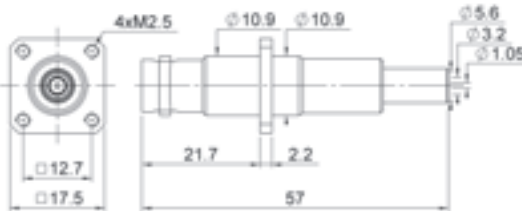

Fig. 2

Cable group	Cable group dia.	Part number	Fig.	Panel Drilling	Captive center contact	Note
RG58/RG141/RG142 RG223/RG400	5/50/S + D	R317 255 000	1	P01	Yes	Square flange clamp type
RG58/RG141	5/50/S	R317 270 000	2		Square flange crimp type	

RECEPTACLES AND ADAPTER

RECEPTACLES

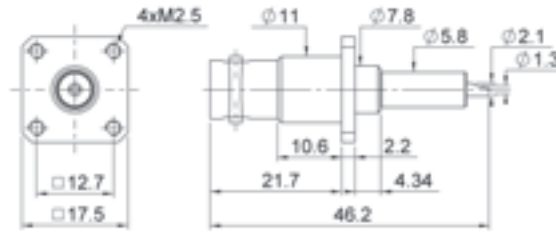

Fig. 1

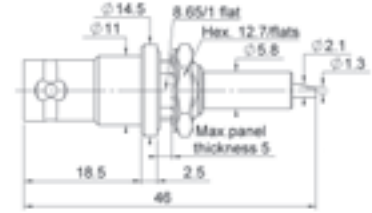
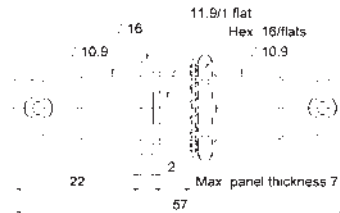

Fig. 2

Part number	Fig.	Panel Drilling	Note
R317 405 000	1	P05	Square flange
R317 580 000	2	P06	Bulkhead

IN SERIES ADAPTER



Part number	Panel Drilling	Note
R317 720 000	P04	Bulkhead jack - jack

CHARACTERISTICS MiniQUICK HT

Snap-on connection with a positive locking system for secure connection.

ELECTRICAL CHARACTERISTICS

Frequency range	DC - 2 GHz
Impedance	50Ω
VSWR (plug and jack)	< 1.20 + 0.3 F (GHz)
Test voltage	unmated connectors: 7 000 V D.C. mated pair: 12 000 V D.C.
Threshold of corona discharge	4 500 V r.m.s. - 50 Hz (LCIE certificate N° 137656C)
Current rating	10 A

MECHANICAL AND ENVIRONMENTAL CHARACTERISTICS

Temperature range	- 40°C + 100°C
Mating cycles	1 000
Vibration	20 g - 2000 Hz
Shock	50 g
Salt spray	48 H

MATERIALS AND PLATING

Components	Materials	Plating
Body	Brass	Nickel chrome
Center contact	Beryllium copper	Gold / Silver
Other metal part	Beryllium copper	Nickel
Insulator	PTFE	
Gasket	Silicone rubber	

All dimensions are given in mm

To download data sheets and assembly instructions, visit www.radiall.com & enter the part number in the Search box.
Bold part numbers represent products typically in stock & available for immediate shipment.
 See page 8 and 9 for packaging information.

STRAIGHT PLUGS, CLAMP TYPE FOR FLEXIBLE CABLES

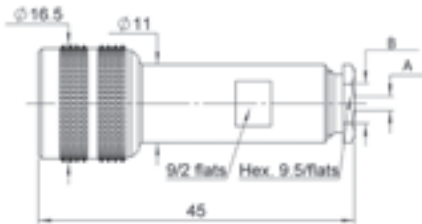

Cable group	Cable group dia.	Part number	Dimensions	
			A	B
RG58/RG141/RG142/RG223/RG400	5/50/S + D	R321 007 000	2	5.6
RG59/RG62	6/75/S	R321 011 000	1.2	6.5

STRAIGHT JACK, CLAMP TYPE FOR FLEXIBLE CABLES

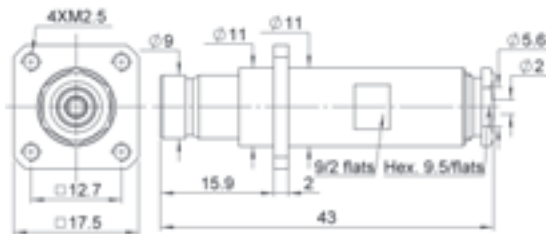

Cable group	Cable group dia.	Part number	Panel drilling	Note
RG58/RG141/RG142/RG223/RG400	5/50/S + D	R321 257 000	P01	Square flange

RECEPTACLES

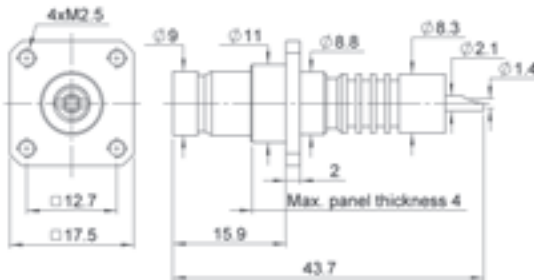

Fig. 1

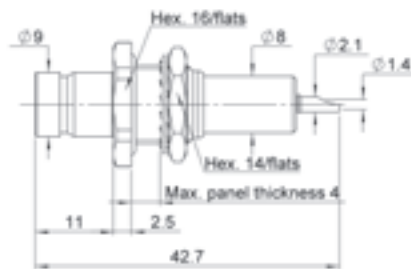

Fig. 2

Part number	Fig.	Panel drilling	Note
R321 405 000	1	P07	Square flange
R321 603 000	2	P08	Bulkhead panel seal

CHARACTERISTICS

Screw coupling.

Female center contact has a 4 mm internal dia. which allows testing with standard banana plugs.

ELECTRICAL CHARACTERISTICS

Frequency range	DC - 1 GHz	
Impedance	50Ω	
Test Voltage	unmated connectors	10 000 V D.C.
	mated pair	20 000 V D.C.
Current rating	20 A	

MECHANICAL AND ENVIRONMENTAL CHARACTERISTICS

Temperature range	- 40°C + 70°C (polyethylene or styramic insulators) -55°C + 125°C (PTFE insulator)
Mating cycles	500
Salt spray	48 H

MATERIALS AND PLATING

Components	Materials	Plating
Body	Brass	Nickel
Center contact	Brass / Beryllium copper	Gold / Silver
Other metal part	Brass	Nickel
Insulator	PTFE / Polyethylene	
Gasket	Silicone rubber	

All dimensions are given in mm

STRAIGHT PLUGS, CLAMP TYPE FOR FLEXIBLE CABLES

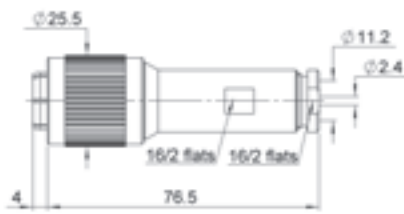

Fig. 1

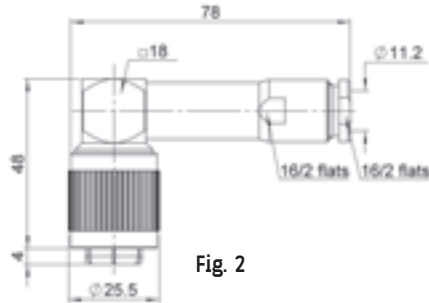

Fig. 2

Cable group	Cable group dia.	Part number	Fig.	Note
RG213/RG393/RG214	10/50+75/S + D + 11/50+75/D	R331 018 000	1	Straight/PE insulator
RG11/RG12/RG144/RG216		R331 168 000	2	Right angle

RECEPTACLES

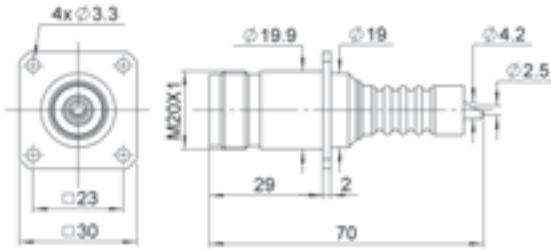

Fig. 1

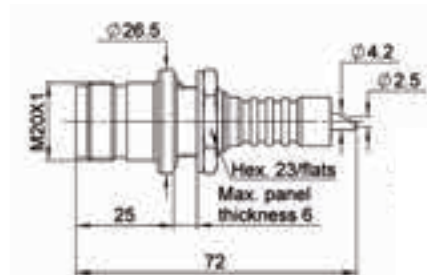
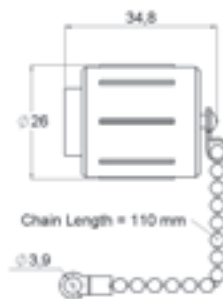

Fig. 2

Part number	Fig.	Panel drilling	Note
R331 405 000	1	P09	Square flange - PTFE insulator
R331 603 000	2	P10	Bulkhead, panel seal PTFE insulator

CAP



Part number	Note
R331 803 000	For THT 20 female connectors. The body of this cap is entirely made of styramic plastic.

To download data sheets and assembly instructions, visit www.radiall.com & enter the part number in the Search box. **Bold** part numbers represent products typically in stock & available for immediate shipment. See page 8 and 9 for packaging information.

PANEL DRILLING

P01

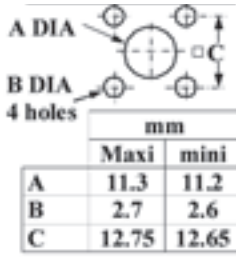

P02

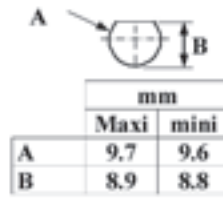

P03

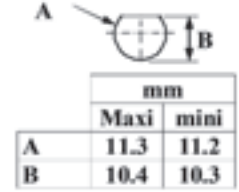

P04

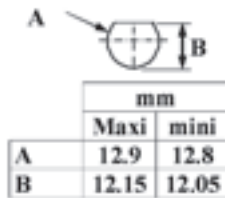

P05

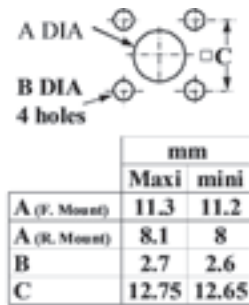

P06

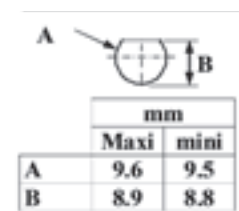

P07

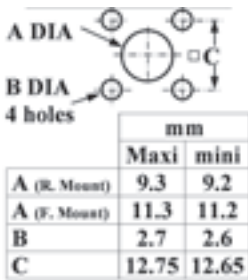

P08

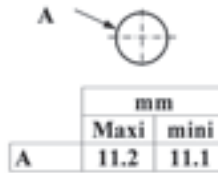

P09

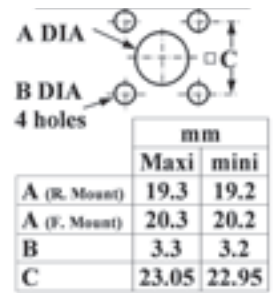

P10

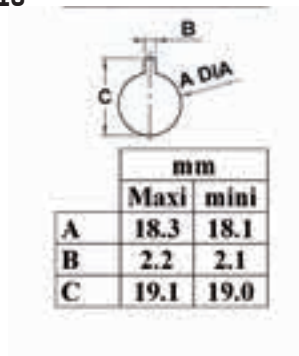



AEROSPACE



AUTOMOTIVE



DEFENSE



INDUSTRIAL



INSTRUMENTATION



MEDICAL



SPACE



TELECOM

EUROPE

France - RADIALL S.A.

101, Rue Ph. Hoffmann
93116 ROSNY sous BOIS (Paris)
Tel.: +33 1 49 35 35 35 - Fax: +33 1 48 54 63 63
E-Mail: info@radiall.com

Finland - RADIALL SF

P.O. Box 202 - 90101 OULU
Tel.: +358 407 522 412
E-Mail: infofi@radiall.com

Germany - RADIALL GmbH

Carl-Zeiss Str. 10 Postfach 200143
D63307 - RÖDERMARK (Frankfurt)
Tel.: +49 60 74 91 07 0 - Fax: +49 60 74 91 07 70
E-Mail: infode@radiall.com

Italy - RADIALL Elettronica S.R.L.

Via Concordia, 5 - 20090 ASSAGO MILANO
Tel.: +39 02 48 85 121 - Fax: +39 02 48 84 30 18
E-Mail: infoit@radiall.com
Regional office: Roma

Netherlands - RADIALL B.V.

Hogebrinkerweg 15b - 3871 KM HOEVELAKEN
Tel.: +31 33 253 40 09 - Fax: +31 33 253 45 12
E-Mail: infofl@radiall.com

Sweden - RADIALL A.B.

Sjöängsvägen 2 - SE-192 72 SOLLENTUNA (Stockholm)
Tel.: +46 844 434 10 - Fax: +46 875 449 16
E-Mail: infose@radiall.com

U.K. - RADIALL Ltd.

Ground Floor, 6 The Grand Union Office Park,
Packet Boat Lane
UXBRIDGE Middlesex UB8 2GH (London)
Tel.: +44 1895 425 000 - Fax: +44 1895 425 010
E-Mail: infouk@radiall.com

NORTH AMERICA

USA - RADIALL USA, Inc.

6825 West Galveston Street
CHANDLER, Arizona 85226
Tel.: +1 480 682 9400 - Fax: +1 480 682 9403
E-Mail: infousa@radiall.com

ALSO REPRESENTED IN

Australia	Hungary	Poland
Austria	Indonesia	Russia
Belgium	Israel	Singapore
Brazil	Korea	Spain
Czech Republic	Latvia	Switzerland
Denmark	Lithuania	Taiwan
Estonia	Malaysia	Thailand
Greece	Norway	Vietnam
	Philippines	South Africa

For the above countries, please contact the local agent or RADIALL at info@radiall.com

ASIA

China - SHANGHAI RADIALL Electronic Co., Ltd.

N° 390 Yong He Road 200072 - SHANGHAI
Tel.: +86 21 66 52 37 88 - Fax: +86 21 66 52 11 77
E-Mail: infosh@radiall.com

Japan - NIHON RADIALL

Shibuya-ku Ebisu 1-5-2, Kougetsu Bldg 405
TOKYO 150-0013
Tel.: +81 3 3440 6241 - Fax: +81 3 3440 6242
E-Mail: infojp@radiall.com

Hong Kong - RADIALL Electronics Ltd.

Flat D, 6/F, Ford Glory Plaza,
37-39 Wing Hong Street
Cheung Sha Wan
KOWLOON HONG KONG
Tel: +852-2959-3833 - Fax: +852-2959-2636
E-Mail: infohk@radiall.com

India - RADIALL India Pvt. Ltd.

25 D, II Phase, Peenya Industrial Area
BANGALORE 560058
Tel.: +91 80 83 95 271 - Fax: +91 80 83 97 228
E-Mail: infoin@radiall.com

