

**CONDENSED SPECIFICATION:**

- THIS PLUG MATES WITH NEXUS TELEPHONE JACK TJ-105.
- THE STRAIN RELIEF CLAMP IS INTENDED FOR USE WITH CABLES APPROXIMATELY .275 OUTSIDE DIAMETER.
- THE SOLDER TERMINALS ARE TINNED AND EACH WILL ACCEPT TWO STRANDED CONDUCTORS OF 404 CIRCULAR MILLS (24 GAGE, 41 STRANDS OF #40 AWG) EXCEPT TERMINAL #1 WHICH WILL ACCEPT ONE CONDUCTOR.
- EACH CONDUCTOR IS OF ONE PIECE CONSTRUCTION - THERE ARE NO JOINTS OF ANY TYPE BETWEEN THE CONTACT AREA AND THE SOLDER TERMINALS.
- THE .281 STACK DIAMETER IS MACHINED AFTER INSERT MOLDING SO THE CONTACTS AND INSULATION ARE FLUSH AND CONCENTRIC.
- THE STAY CORD ANCHOR WILL WITHSTAND A 50 POUND PULL FOR AT LEAST 5 MINS.
- THE CONCENTRICITY OF THE BALL END OF THE PLUG TO THE .281 DIA. IS SUCH THAT THE PLUG WILL FREELY ENTER A RING GAGE HAVING A MAX. INTERNAL DIA. OF .284 FOR A LENGTH OF .730 & A MAX. INTERNAL DIA. OF .254 FOR A LENGTH OF .175 WITH NO FORCE EXCEPT ITS OWN WEIGHT.
- MATERIALS:
  - CONTACTS - NICKEL-COPPER ALLOY PER FEDERAL SPEC. QQ-N-281, (MONEL).
  - STACK INSULATION -
  - STRAIN RELIEF CLAMP - STAINLESS STEEL PER FEDERAL SPEC. QQ-S-766 CLASS 4.
  - SHELL - BLACK.
- ELECTRICAL:
  - DIELECTRIC STRENGTH - 500 VOLTS RMS MIN. BETWEEN ANY PAIR OF CONTACTS.
  - INSULATION RESISTANCE - 100 MEGOHMS MIN. BETWEEN ANY PAIR OF CONTACTS.
  - CONTACT RESISTANCE - WHEN MATED WITH NEXUS TJ-105 TELEPHONE JACK AND WITH DIRECT CURRENT OF 100 MILL-AMPERES AT 5 VOLTS (OPEN CIRCUIT VOLTAGE) FLOWING THROUGH THE CONTACTS, THE POTENTIAL DROP BETWEEN EACH PAIR OF CONTACTS WILL NOT EXCEED .005 VOLTS.

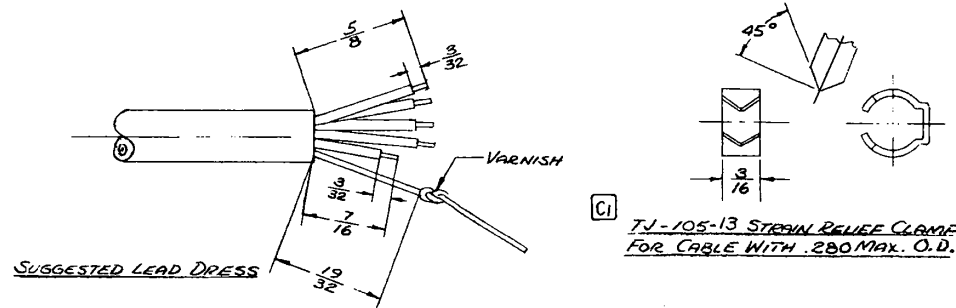
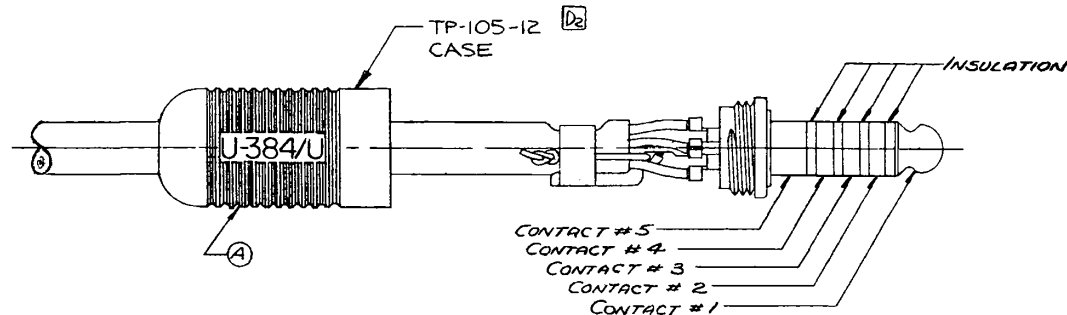

DESIGNED BY R.W.F.	DATE 5/10/67	MATERIAL
CHECKED BY		FINISH
APPROVED BY		WEIGHT
		SCALE 2:1 & 4:1
UNLESS OTHERWISE SPECIFIED DIMENSIONS ARE IN INCHES TOLERANCES BY FRACTIONS DECIMALS ANGLES		TITLE TELEPHONE PLUG
L.T.		SIZE DWR. NO. C TP-105
REVISION	DATE	SHEET OF