

ITEM #	PART #	QTY	DESCRIPTION	MATERIAL
1	SEE TABLE #1	1	SHELL ASS'Y	GLASS FILLED NYLON & 303 SS
2	AP-125-6	1	INSERT ASS'Y	DIALLYPHTHALATE, TYPE SDGF & GOLD PLATED BRASS
3	AP-105-5	1	STRAIN RELIEF	NYLON
4	AP-116-3	1	WASHER	RUBBER
5	AP-116-7	1	NUT ADAPTER	ALUMINUM, ANODIZED
6	SEE TABLE #1	1	BUSHING	RUBBER
7	SEE TABLE #1	1	WASHER	STAINLESS STEEL
8	SEE TABLE #1	1	SPRING	302 STAINLESS STEEL
9	AP-116-6	1	STUD	ALUMINUM ALLOY, ANODIZED

C AP-125

TABLE #1						
AUDIO PLUG #	MILITARY PART #	SHELL ASS'Y	Ø CABLE	BUSHING	WASHER	SPRING
AP-125/1	M55116/1-1	AP-125-1	Ø .165 ± .010	AP-116-17	AP-116-2	AP-116-4
AP-125/2	M55116/1-2	AP-125-2	Ø .228 ± .010	AP-116-18	AP-116-2	AP-116-4
AP-125/3	M55116/1-3	AP-125-3	Ø .250 ± .010	AP-116-8	AP-116-2	AP-116-4
AP-125/4	M55116/1-4	AP-125-4	Ø .290 ± .010	AP-116-19	AP-116-2	AP-116-4
AP-125/5	M55116/1-5	AP-125-5	Ø .320 ± .010	AP-116-20	AP-116-22	AP-116-21

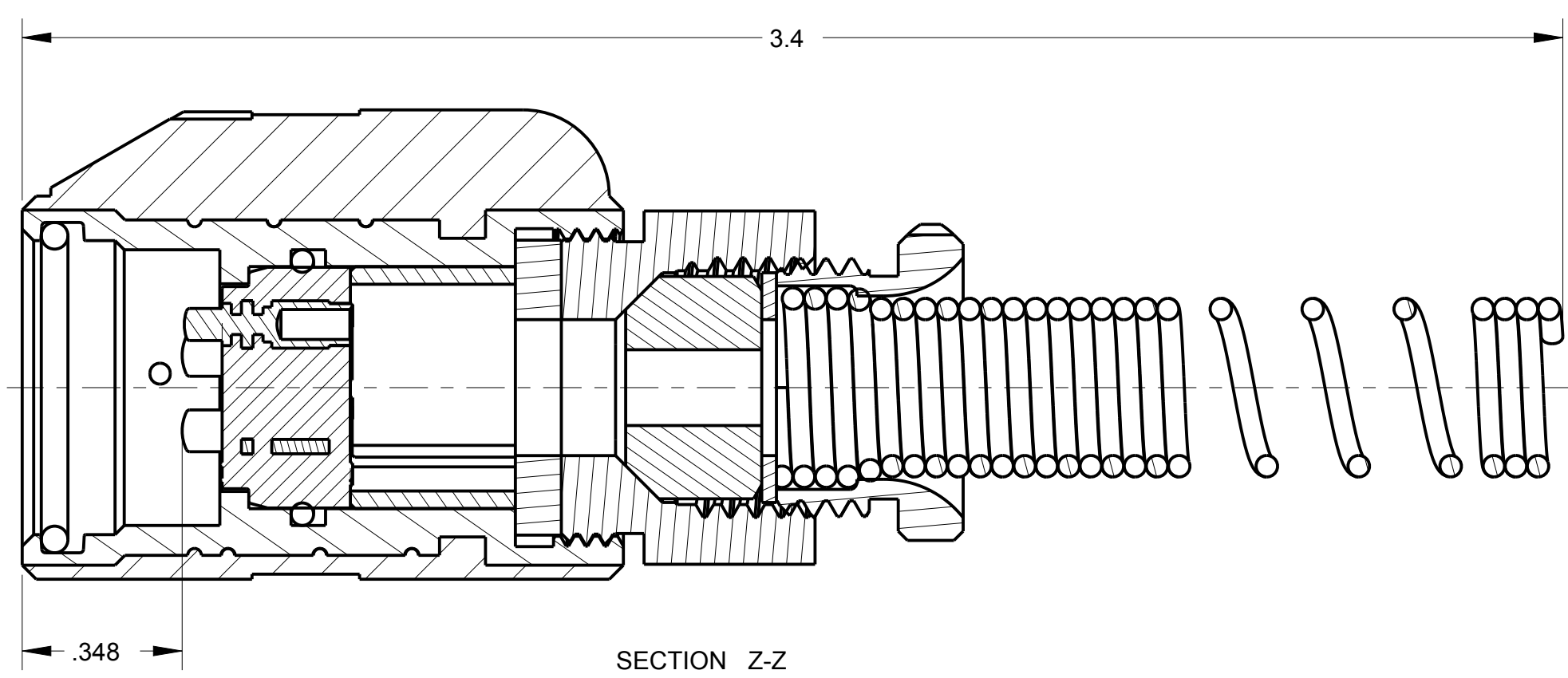
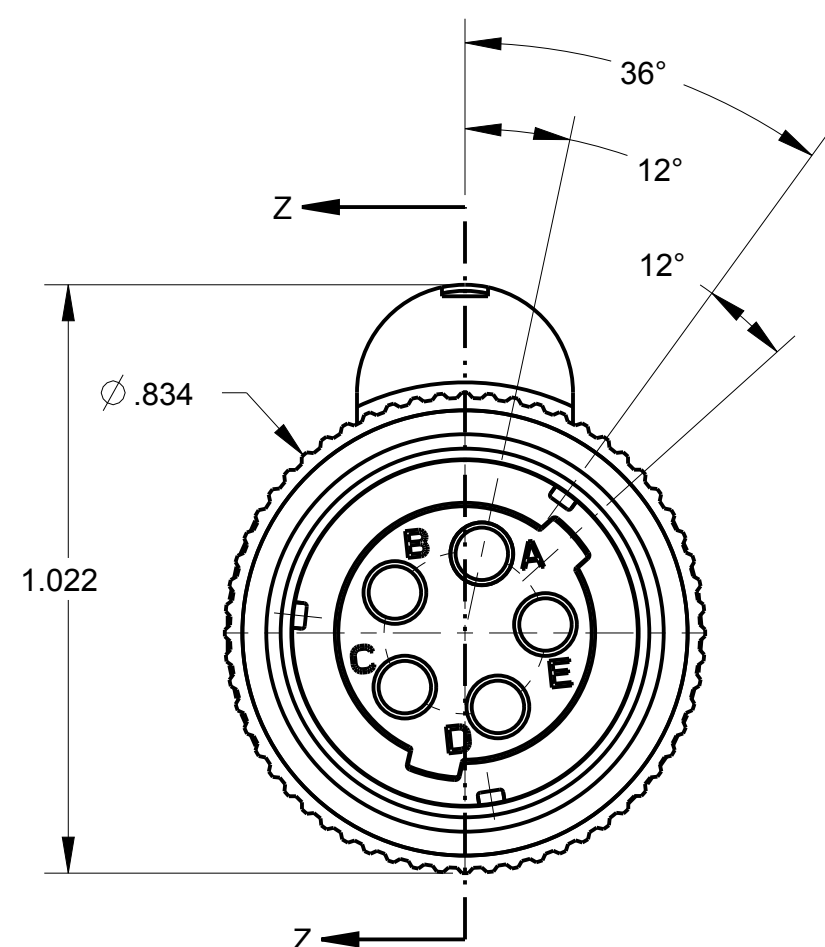
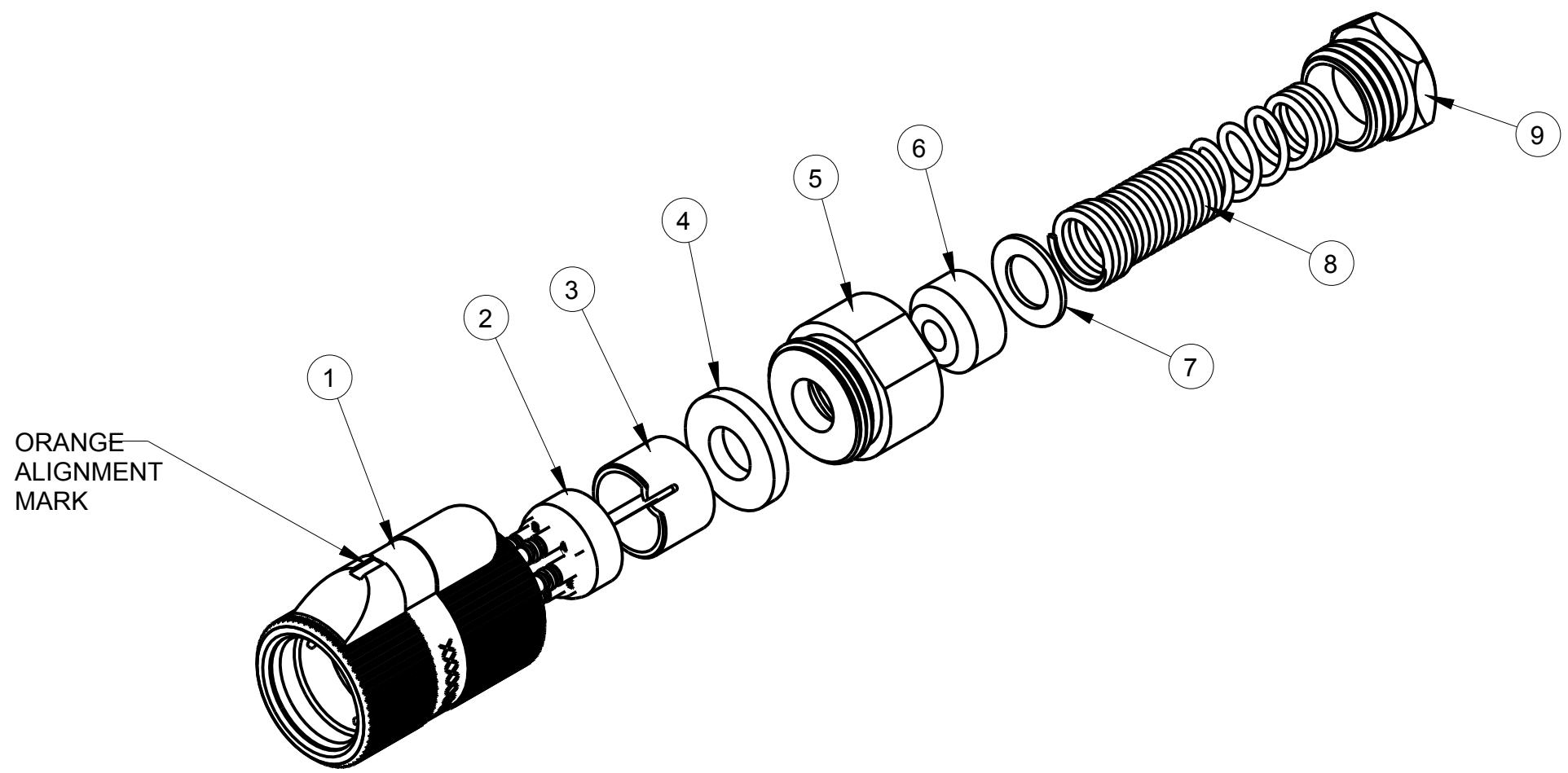

NOTES:
 1) UNLESS OTHERWISE SPECIFIED, CONNECTOR MEETS ALL GENERAL REQUIREMENTS & SPECIFICATIONS OF MIL-C-55116

THIS DOCUMENT CONTAINS PROPRIETARY INFORMATION OF NEXUS, INCORPORATED AND SUCH INFORMATION MAY NOT BE DISCLOSED TO OTHERS FOR ANY PURPOSE OR USED FOR ANY PURPOSE WITHOUT THE WRITTEN CONSENT OF NEXUS.

Australian Representatives
ROJONE, PTY LTD.
 Tel: 02 9829 1555
 E: sales@rojone.com.au
 www.rojone.com.au

				DWN BY	MNF	DATE	2/4/97	MATERIAL
				CHECKED BY	L SMITH	DATE	9/9/97	FINISH
				APPR BY	L SMITH	DATE	9/9/97	WEIGHT
				UNLESS OTHERWISE SPECIFIED DIMENSIONS ARE IN INCHES & OR (mm)				SCALE = 1.00 : 1
				TOLERANCES:				TITLE
				DECIMAL:				
				±.XX(X.X) ±.XXX(X.XX) ±.XXXX(X.XXX)				AUDIO PLUG
				±.01(0.3) ±.003(0.08) ±.0005(0.013)				
				FRACTION: ±X/XX ± 1/64				DO NOT SCALE DWG.
				ANGLES: ±X ° ±.5 °				SHEET 1 OF 1
								NEXUS STAMFORD, CONN